

**ASSOCIATION OF
AUTHORISING
BODIES**



RULES & REGULATIONS

2019 EDITION

CLASS 7



"The Association reserve the right to alter/amend the Rule Book as required, and that the Association has the right to review and amend any Class or Construction Rules at the end of each racing year."

**VALID FROM JANUARY 2019
UNTIL FURTHER NOTICE**

ALL PREVIOUS EDITIONS ARE INVALID

IT IS THE RESPONSIBILITY OF THE DRIVER/CONSTRUCTOR TO ENSURE THAT ALL VEHICLES CONFORM FULLY TO THE REGULATIONS AND RULES CONTAINED WITHIN THIS RULEBOOK.

IF THE REGULATIONS AND RULES DO NOT STATE THAT "YOU CAN DO IT" THEN IT MUST BE PRESUMED THAT IT CANNOT BE DONE.

CLASS 7

**FOR GENERAL BASIC CONSTRUCTION RULES (i.e. Basic requirements for all class of saloon vehicle).
SEE SEPARATE RULE BOOK –SALOONS - GENERAL**

CLASS 7

INDEX	PAGE
CLASS SPECIFICATION - 7	1
1 Engine/Transmission	1
2 Chassis/Body Shell	2
3 Windscreen Glass	8
4 Steering	8
5 Safety Harness	8
6 Seat	8
7 Fire Extinguisher	8
8 Identification	8
9 Electrical / Instruments	8
10 Fuel	9
11 Cooling Systems	9
12 Brakes	10
13 Wheels	10
14 Tyres	10
15 Exhaust	11
16 Safety Shields	11
17 Suspension	12
18 Protection	12
19 Ballast	13
20 Check Sheet	13
FIGURES	15

CLASS SPECIFICATION - CLASS 7.

May be a rear wheel drive saloon, sports saloon, or specified dual-purpose vehicle.

A vehicle produced and marketed by a recognised automobile manufacturer, may be taken in its entirety, and modified. See Rule 2.1 for Permitted & Non-Permitted vehicle information.

a). **STATEMENT of CONFORMITY.**

Only methods of construction and modifications as listed are permitted. Any further modifications, other than those permitted, are prohibited. Any modifications other than those listed within the Vehicle Construction Rules are specifically excluded.

i.e. If the regulations and rules do not state that “you can do it” then it must be presumed that it cannot be done.

- b). A suitable Rear Wheel Drive (RWD) or Front Wheel Drive (FWD) saloon (including permitted three and/or five door “Hatchback” saloons, permitted 2 door saloons and dual purpose vehicle), produced and marketed by a NASA recognised automobile manufacturer, may be taken in its entirety and modified.

1 ENGINE / TRANSMISSION1.1 **Permitted Engine.**

A single engine or twin engine may be used (See definitions).

The original engine manufacturer’s engine identification numbers must remain and be legible.

Minimum cubic capacity – Free.

Maximum cubic capacity – Free.

Prohibited Engines.

Engines to Class 1, 2, 4 and 5 specification.

Note.

The list of prohibited engines is not fixed.

It is the Competitors and/or race vehicle constructor’s responsibility to contact a Scrutineer to confirm that the engine chosen is eligible before using it in the vehicle.

NASA reserves the right via an appointed Official and or Scrutineer to permit, reject and or prohibit an engine as being suitable or unsuitable for Class 7 Autograss racing at any time.

Engine & Transmission – Materials.

The engine materials and gearbox/transmission materials - Free.

Engine Modification.

Free.

Forced Induction – Restricted.

The use of “Forced Induction” i.e. the fitting an engine with a Supercharger and/or Turbocharger is permitted on NASA defined “Car” engines only. (See section – DEFINITIONS).

For an engine fitted with forced induction i.e. a Supercharger and/or Turbocharger, the cubic capacity (cc) is free.

Note:

- i. The use of forced induction on a single “Motorbike”, “Motorcycle” “Motorbike Type” and or “Motorbike/cycle conjoined” engine is prohibited.
- ii. The use of forced induction for a ‘Twin Engine’ installation is prohibited.

For “Single Engine Installation”:

The engine may be sourced from a NASA permitted “Car” or “Motorbike/cycle”. (See definitions).

For ‘Twin Engine Installation’:

The engine may be sourced from a NASA permitted “Car” or “Motorbike/cycle”. (See definitions).

- i. The use of “Forced Induction” is prohibited.
- ii. The use of 2 No. engines including “Motorcycle or Motorbike type” engines permitted.
- iii. Minimum cubic capacity normally aspirated = Free.
Maximum cubic capacity normally aspired = 4000cc (4 Litres) (2.0 Litres each).
- iv. Both engines must be of the same original manufacturer, including model, type and cubic capacity (cc) rating.
- v. Both engines must be located in the same “Single engine compartment”. The Engine compartment must be within the vehicle silhouette.
- vi. The complete “Twin Engine” installation and the transmission system(s), including each engine & transmission unit throttle, clutch and gear change mechanism control systems must be such that they operate simultaneously as one complete unit at all times. The temporary dis-engaging of one engine or transmission or ignition or throttle or clutch or gear change mechanism control system is prohibited. There will be a random spot check upon the starting line in order to check that any engine or gearbox or transmission or any part of the gearbox or gears or transmission or ignition or throttle or clutch or gear-change mechanism control systems are not temporarily disconnected.
- vii. Both engines and their associated transmission drives must provide motive power to the vehicle driving wheels via a single common ‘drive shaft’ at all times. Devices that “Split” the drive are prohibited.

1.2 **Gearbox/Transmission - Type.**

Free.

Driveshaft type free.

Wheel Hubs free, but must be of metal.

1.3 **Engine & Transmission/Gearbox Location – Restricted.**

The engine and transmission may be positioned & fitted anywhere within the chassis except for the area between the front roll cage hoop and the rear of the driver’s compartment.

i.e. The location of the engine & transmission compartment may remain as per the original manufacturer’s specification for the particular vehicle’s body-shell or be moved to a different location.

The conversion of a FWD vehicle to a RWD vehicle is permitted.

- 1.4 Engine/Gearbox Mountings/Cradle.
Engine/Gearbox Mountings/stabilisers free. However they must be sufficient for size and weight of engine/gearbox and stress loadings involved.
Engine/Gearbox Cradle mountings and construction must be fit for purpose. Excessive construction is regarded as ballast/reinforcement and prohibited.
- 1.5 Gear Lever.
A single gear lever or operating device must be fitted to control the operation of the transmission system 'gear change' mechanism for the engine or engines.
The use of 'sub-levers or devices' to independently control the gear change system for each engine or transmission in twin-engine installations is prohibited.
- 1.6 Clutch Operation – Restricted.
A single clutch pedal must be fitted to control the operation of the 'clutch mechanism or engaging' drives to the transmission system mechanism from the engine or engines.
The use of 'sub-pedals or devices' to independently control the clutch mechanism system from each engine or transmission in twin-engine installations is prohibited.
Clutch type and modifications to are free.
- 1.7 Drive.
Drive must be effected by the two rear wheels only as per Class specification.
- 1.8 Differential.
Free.

2 CHASSIS/BODY SHELL

- 2.1 The original vehicle may be modified in accordance with the regulations and the class construction requirements.
The removal of the original vehicle floorpan and fitting of a substitute metal floor and floor-frame with integral roll cage structure incorporated into the vehicle then the construction of a complete steel tube "Rolling" chassis space-frame" and the attachment of a body-shell is permitted.
Note.
i). The bodyshell including all associated panels, roof, bulkhead floorpan and panels must be securely fixed to the chassis space-frame and roll cage. The floor frame and roll cage chassis space-frame must be an integral part of the whole vehicle and bodyshell construction.
There must also be a minimum of two (2) front area and two (2) rear area upper bodyshell fixings (Bolt size 8mm HT or greater) at nearside and offside. These must be at a level that is at or above the door window aperture bottom.
Note.
NASA reserves the right via a Scrutineer to reject a fixing method choice due to size and ability and or capacity to provide the necessary secure fitment of the bodyshell to the chassis space-frame and roll cage.
- ii). Composite material panels:
The use of non metal automotive "Composite material" panels attached to a metal bodyshell permitted only on vehicles with such panels fitted by the original vehicle manufacturer as standard production items to that make and model.
- iii). Permitted Vehicles – Restricted.
It is Competitors responsibility to contact a scrutineer and or designated official to confirm that the chosen donor vehicle is eligible. i.e. permitted by the NASA Scrutineers Committee **before** using it.
The following are examples of permitted vehicles:
Vehicles that comply with class specification including: Permitted three and/or five door "Hatchback" saloons, permitted 2 door saloons, permitted Dual Purpose models.
- Permitted Dual Purpose Vehicles:
Mini Estate.
Mini Pick-up.
Skoda Pick Up.
VW Golf Pick Up.
- iv). Prohibited Vehicles See Check Sheet.
- 2.2 Trim Removal & "Skinning" –Restricted.
Trim removal, including removal of non-metal body components.
Where the above is carried out and other components removed leaving apertures then, there must also be a metal covering maximum thickness 0.91mm (20 gauge), fitted as the original vehicle silhouette, in place of any removed non-metal body components
- "Skinning".
Skinning of panels is allowed. See Definitions.
Note.
Where the original floor is retained the Inner "B" Post, inner windscreen pillars, inner sills and all structural elements must remain in place.
Excessive skinning is not permitted. The bodyshell must retain structural integrity. The bodyshell must be securely fixed to any internal floor frame and the roll cage structure.

2.3 Doors.

Doors may be “skinned”.

Nearside/Passenger’s door.

Where a driver is centrally seated both the offside/driver's and nearside/passenger door MUST be retained at the standard manufactured height.

The cutting down of the nearside/passenger door may be permitted subject to driver stature.

NASA reserves the right via an appointed Official and or Scrutineer to permit, reject and or prohibit the cutting down of the nearside/passenger door as being suitable or unsuitable for the driver stature racing at any time.

2.4 Original Engine compartment bonnet or cover.a). Front Engined Vehicles.

This must be of metal and retain its original shape and silhouette except for the plan area necessary to provide a Carburettor/air filter cover as described in b).

- i). The rear part of the engine compartment bonnet or cover must remain flush with the front windscreen scuttle at all times.

Failure to comply with this is a Black Flag (Race Disqualification) offence.

- ii). It is permitted to make a hole for carburettor(s) and/or air filter(s) to protrude through the engine compartment bonnet or cover. However the items that protrude through must be completely covered and shielded with metal.

The shield dimensions are restricted to the following:

Height: maximum of 160mm (6”) from the original engine bonnet or cover surface.

Plan Area: Absolute minimum necessary to provide the shield.

Note.

Any removable or hinged access panel fitted into the carburettor/air filter shield must remain closed/shut at all times whilst the vehicle is taking part in a race. Failure to comply with this is a Black Flag offence.

b). Rear engined Vehicles.

This must be of metal and retain its original shape and silhouette.

Removal or “skinning” of strengthening braces/ribs permitted.

Bonnet hinges may be retained or removed.

2.5 Front Bulkhead.

The original front passenger compartment to front engine and or front luggage compartment bulkhead may be modified, retained or removed and replaced.

a). All Vehicles – Front Bulkhead.

A complete steel front bulkhead **must** be fitted. This bulkhead may be the complete original vehicle steel bulkhead or a substitute/replacement steel sheet bulkhead (Statutory minimum thickness 20 gauge) or a repaired original bulkhead (Repair material - steel sheet statutory minimum thickness 20 gauge).

Note.

The Bulkhead including any foot-pedal indent must always be to the rear of an imaginary line connecting the nearside and offside front hub centres and also more than 230mm (9”) from the front face of the front engine/front suspension cradle. See Fig. 29, 32, & 33.

Original Bulkhead.

If the original front bulkhead is retained it must remain in its original location with all points of connection to the bodyshell side, dashboard/front windscreen and floor-pan areas. i.e. The bulkhead must be complete from the inside surface of the nearside bodyshell to the inside surface of the offside bodyshell. There must be no gaps between bulkhead and bodyshell inside. Ceasing of the bulkhead at the either or both of the roll cage uprights is prohibited. See Fig. 29. Also (see Rule 2.7d.).

Replacement Bulkhead.

It is permitted to remove the complete bulkhead and replace it with metal sheet, minimum thickness 20 gauge (0.91mm).

If the front bulkhead is not original, then it may be fitted in the original location of the original front bulkhead position or fitted in a non- standard production location.

However it must be fitted with all points of connection to the bodyshell side, dashboard/front windscreen and floor-pan areas. i.e. The bulkhead must be complete from the inside surface of the nearside bodyshell to the inside surface of the offside bodyshell. There must be no gaps between bulkhead and bodyshell inside. Ceasing of the bulkhead at the either or both of the roll cage uprights is prohibited. See Fig. 29. Also (see Rule 2.7d.).

b). Front Bulkhead Modification.All Vehicles.

- i). The upper bulkhead area directly behind the main vehicle instrument panel may be modified to accommodate the battery, carburettor and air filter, fuel tank, and engine ancillaries.

However the driver's compartment must be protected from the engine compartment by a bulkhead/fire shield.

- ii). Slight local modification of the lower front bulkhead and floorpan is **only** permitted for:

Localised clearance of mechanical components. (As a “Rule of thumb” “Localised clearance” is regarded as approx. 100mm clearance).

- lii). The Bulkhead including any foot-pedal indent must always be to the rear of an imaginary line connecting the nearside and offside front hub centres and also more than 230mm (9”) from the front face of the front engine/front suspension cradle. See Fig. 29, 32, & 33.

Note:

The driver's feet must remain at all times to the rear of the driver's compartment face of the original front bulkhead location. See Fig. 32. & 33. See also Rule 2.7.

2.6 Rear Bulkhead.Front Engine FWD BodysHELLS only – Rear Bulkhead.

For manufacturer's original specification front engine vehicles, the original rear passenger compartment to luggage compartment bulkhead/engine fire shield may be modified, retained or removed.
If the original rear passenger compartment to luggage compartment bulkhead is retained it must remain in its original location.

Retention of original rear bulkhead - Modification.

If the original rear passenger compartment to luggage compartment bulkhead is retained.

- a). The upper bulkhead area directly below the rear window panel may be modified to accommodate the battery, carburettor and air filter, fuel tank, and engine ancillaries.

However the driver's compartment must be protected from the engine compartment by a fire shield/bulkhead. i.e. voids formed for the accommodation of above items must be made good and filled in with metal.

- b). Slight local modification of the lower rear bulkhead and floorpan is **only** permitted for:

Localised clearance of mechanical components. (As a "Rule of thumb" "Localised clearance" is regarded as approx. 100mm clearance).

Rear engine RWD & Converted FWD to RWD bodysHELLS only – Rear Bulkhead/engine fire shield.

The original front passenger compartment to rear engine compartment bulkhead/engine fire shield may be retained, modified, or removed and replaced.

a). Original Bulkhead.

If the original rear bulkhead/engine fire shield is retained it must remain in its original location with all points of connection to the bodysHELL side, rear window and floor-pan areas. i.e. The bulkhead must be complete from the inside surface of the nearside bodysHELL to the inside surface of the offside bodysHELL. There must be no gaps between bulkhead and bodysHELL inside. Ceasing of the bulkhead at the either or both of the roll cage uprights is prohibited. See Fig. 29. Also (see Rule 2.7d.).

b). Replacement Bulkhead.

It is permitted to remove the complete original bulkhead/engine fire shield and replace it with metal sheet, minimum thickness 20 gauge (0.91mm) as described in rule 16.1.

2.7 Front Engine Compartment - Inner Wings & Chassis & Slam Panel.

Free modification to the vehicle original manufacturer's front engine compartment inner wings and chassis rails and floorpan forward of the front bulkhead is permitted for the fitting and provision of localised clearance for: -

- a). The engine and its ancillaries and associated components. i.e. engine block & cylinder head(s), distributor, oil and/or water pumps, carburettor(s), inlet and exhaust system manifolds and pipework including their associated support brackets/cradle.
b). The suspension and steering systems and their associated components. i.e. struts/shock absorbers, springs, wishbones, arms, and support brackets/cradle.
c). To facilitate the fitting of non-original size of tyre & wheel assembly.
d). To facilitate a combination of a). b). & c).
e). All support bars forward of the front face of the front tyres must have a wall thickness no greater than 3.5mm.

Note.

Where the above is carried out and other components removed leaving apertures then, there must also be a metal covering maximum thickness 0.91mm (20 gauge), fitted as the original vehicle silhouette, in place of any removed non-metal body components.

The following also applies:

i). Slam Panel.

The slam panel may be removed or retained.

Where it is removed there must be a substitute bonnet single steel tube support bar (Maximum 20mm circular/box section) fitted in its place. This "Substitute slam panel bar" must not protrude more than 20mm from the inside edge of each of the front wings, outward, on each side of the vehicle.

ii). Front Panel Support Bar.

There must also be a single steel tube panel support bar (Maximum 25mm box or 25mm circular section) fitted immediately behind the front panel/metal covering, from nearside to offside to securely hold (i.e. bolted or welded) the metal covering / front panel in place. The panel support bar must not protrude beyond the inside rim of each of the front wheels on each side of the vehicle when the wheels are parallel. This support bar must have a minimum of 1 (One) bar maximum of 4 (Four) bars (Maximum 20mm box or 20mm circular section) connecting it to the suspension cradle. See Fig 24.

Note.

The suspension cradle connecting bars must not be joined together at a single point of connection on the panel support bar. There must be a minimum of 300mm in a horizontal plane, between each connecting bar at the point of connection to the panel support bar.

Any gusseting must be at a point that is a minimum of 150mm from the panel support bar.

iii). Front Suspension/Front Engine Cradle.

The suspension/engine cradle framework must be of steel tubular construction of minimum thickness 2.5mm. It must be securely fixed (Bolted or welded) to the vehicle front bulkhead/chassis/floorpan etc. The width is free provided the location of the wheel and tyre assembly complies with Rules 2.14 & 2.15. The suspension/engine cradle construction may include 20mm "cross bars".

All components of the front suspension/engine cradle must not protrude beyond the front surface of the engine block.

The only exception to this is for an engine compartment mounted radiator. The radiator/engine cradle must then terminate at the front surface of the radiator.

Note.

The choice of engine and radiator combinations and their potential and actual overall dimensions must be considered during construction to ensure compliance regardless of competitor donor bodyshell choice and overall fit within the vehicle silhouette.

iv. Front Suspension Cradle – Rear Engine Vehicles.

The suspension cradle framework must be of steel tubular construction of minimum thickness 2.5mm. It must be securely fixed (bolted or welded) to the vehicle front bulkhead/chassis/floorpan etc. The width is free provided the location of the wheel and tyre assembly complies with Rules 2.15 & 2.16. The suspension/engine cradle construction may include 20mm “cross bars”.

All components of the front suspension/engine cradle must not protrude beyond the front surface of the front tyres.

Note.

The choice of front wheel & tyre combinations and their potential and actual overall diameters must be considered during construction to ensure compliance regardless of competitor wheel & tyre choice during racing.

2.8 Floorpan.

A complete steel floor pan including the transmission/gear linkage/exhaust tunnel from the front bulkhead extending to the back of the rear roll cage feet **must** be fitted. This floorpan may be the complete original vehicle steel floorpan or a substitute steel sheet floorpan (Statutory minimum thickness 20 gauge) or a repaired original floorpan (Repair material - steel sheet statutory minimum thickness 20 gauge).

Note.

- i. The original location of the floorpan in the vertical plane is regarded as the lower edge of the original manufacturer's outer sill of the vehicle when viewed from the side.
- ii. The original location of the floorpan in the horizontal plane is regarded as a horizontal line from the lower edge of the original manufacturer's outer offside sill to outer nearside sill across the vehicle.
- iii. Where the Driver is centrally seated the Transmission/gear linkage/exhaust tunnel may be retained or removed.

iv. Sill Location – Restricted.

Where the original floor is retained and or repaired, then the sill must remain in its standard production location.

The depth of any sill fitted with a complete replacement steel floorpan must be:

- (i). A minimum of 50mm (2”) from the base or bottom of the original vehicles' doors.
- (ii). For certain specified vehicles only a minimum of 20mm (3/4”) from the base or bottom of the original vehicles' doors. N.B. Applications for consideration and or permission for other non-listed vehicles must be made to NASA **before** use as a donor vehicle.
Specified vehicle: VW Polo, year 2002 onwards.

Original Floorpan retained.

If the original floorpan is retained it must remain in its original location.

Original Floorpan retained - Suspension mounting cross member.

Where the original floor is retained in its entirety (See Fig.7) a suspension mounting cross member may be attached to the vehicle at low level (i.e. within 250mm (10”) of floorpan) and or via the original rear lower suspension component and or for Mini vehicles the rear sub frame mounts, 10 BSG x 1½” box section or permitted suitable equivalent. (See Fig.8).

Original Floorpan replaced with steel floor & Floor frame.

For a vehicle that is constructed/fitted with a complete steel tube “rolling” chassis space-frame” a complete steel floor must be fitted from the front bulkhead extending to the rear of the rear roll cage upright. The floor from this point to the rear of the vehicle (including rear luggage compartment floor and inner wheel arches may be in a non original location and material but must be fitted and be of metal of minimum 0.91mm thickness.

Replacement steel floor with Floor frame – Thickness verification/drain holes.

There must be a single inspection hole of a minimum of 40mm diameter fitted in the floor panelling. It is permitted to fit a maximum of 1 No. per floor frame triangle, additional “Air / “Cleaning / draining holes” into the chassis floor panelling , each hole diameter free up to a maximum of 50mm diameter. i.e. where there are 6 No. triangles a maximum of 6 holes may be fitted, one of which shall be the inspection hole.

2.9 Rear Engine Compartment - Inner Wings & Chassis & Slam Panel.

Free modification to the vehicle original manufacturer's rear engine compartment inner wings and chassis rails and floorpan rearward of the front bulkhead is permitted for the fitting and provision of localised clearance for: -

- a). The engine and its ancillaries and associated components. i.e. engine block & cylinder head(s), distributor, oil and/or water pumps, carburettor(s), inlet and exhaust system manifolds and pipework including their associated support brackets/cradle.
- b). The suspension system and their associated components. i.e. struts/shock absorbers, springs, wishbones, arms, and support brackets/cradle.
- c). To facilitate the fitting of non-original size of tyre & wheel assembly.
- d). To facilitate a combination of a). b). & c).
- e). All support bars rearward of the rear face of the front tyres must have a wall thickness no greater than 3.5mm.
- f). All components of the rear suspension/engine cradle must be contained within the bodyshell and rear engine bonnet/cover.

Note.

Where the above is carried out and other components removed leaving apertures then, there must also be a metal covering maximum thickness 0.91mm (20 gauge), fitted as the original vehicle silhouette, in place of any removed non-metal body components.

2.10 Floorpan (Front, Centre & Rear).

The front, centre, and rear areas to the back of the rear roll cage feet of the vehicle floorpan may have local or slight modifications for localised clearance of mechanical components.

Note.

All apertures formed or cut into the floor-pan to allow the fitting of the above mechanical components must be filled in and made good with steel material such that there is a complete floor-pan. The material must provide a mechanical component cover and/or transmission tunnel/cover and/or shield of steel with a minimum thickness of 0.91mm (20 gauge) and fully welded in place. No mechanical component shall be visible or accessible from the interior and/or inside of the bodyshell. The use of non-ferrous metal and/or pop rivets for floor and or tunnel construction is not permitted.

Rear Suspension/Rear Transaxle/Beam Axle Cradle.

The suspension/beam axle cradle framework must be of steel tubular construction. Tube must be of minimum wall thickness 2.5mm. The cradle must be securely fixed (bolted or welded) to the vehicle chassis/floorpan/floor frame etc. The width is free provided the location of the wheel and tyre assembly complies with Rule 2.15.

The amount of rearward protrusion of the suspension/engine cradle is restricted. All components of the cradle must not protrude beyond the rear surface of the rear tyres.

The suspension/axle cradle construction may include 20mm “cross bars”. However excess framework material will be deemed as ballast and prohibited.

Note.

“Heavy Duty” or over large cradle construction may be regarded as ballast.

The choice of rear wheel & tyre combinations and their potential and actual overall diameters must be considered during construction to ensure compliance regardless of competitor wheel & tyre choice during racing.

2.11 Cross Member & Cross Brace.

If any part of the vehicle floor, including any transmission/gear linkage/exhaust tunnel is removed or repaired or replaced and/or substituted with steel sheet (statutory minimum thickness 20 gauge) then, items a. and b. and c. and d. must be fitted.

Item b. must also then be incorporated within the roll cage structure i.e. connected to the rear brace bars and rear roll cage hoop uprights (See Fig. 20a). Item b. may also be used as a suspension mounting point.

- a. A metal cross member fixed to the floorpan and body at low-level (i.e. within 250mm (10”) of floorpan), minimum size 38mm x 38mm box or circular section steel tube with 2.5mm wall thickness. (See Saloons General - Roll Cage - Rule 4). This cross member may also be used as a suspension mounting point.
- b. A steel cross brace fixed above the rear wheel arch, below the rear side window aperture and across the interior between the offside and nearside minimum 30mm x 30mm box section tube, 32mm(1¼”) circular section tube – with specified wall thickness as Saloons General - Roll cage Rule 4.
End plates 75mm x 50mm x 3mm (3” x 2” x ⅛”) must be welded to both the cross member and cross brace and be bolted (minimum 2 No. 10mm or ⅜” bolts) through the body skin to a plate of equivalent size on the outside (See Fig 9).
- c. Floor Frame as described in rule 2.12.
- d. Where the bodyshell construction makes the use of end plates impractical, then the cross brace/cross member must be fitted in a permanent manner. i.e. CROSS BRACE fully welded or bolted to vehicle by means of steel sandwich plates through the vehicle side. CROSS MEMBER BRACE fully welded or bolted to vehicle by means of steel sandwich plates through the vehicle floor /side.
- e. There must be an “X” or 2 “Cross” bars of steel tube box section 25mm x 25mm minimum, 50mm x 50mm maximum or round (circular) section 25mm diameter minimum, 50mm diameter maximum, all with a minimum thickness of 2.5mm, fixed on top of the vehicle floor diagonally from offside rear corner to nearside front corner and nearside rear corner to offside front corner welded into the floor frame prescribed in c. above and rule 2.12.

2.12 Floorpan Cross Member & Floor Frame.

- a). The cross member described in 2.11a above must be extended forwards up to the front bulkhead, to form a steel strengthening “floor frame” with bars as specified in Saloons General - Roll cage rule 4.
- b). Steel plates (minimum surface area 150 sq mm (6 sq”)) to be fixed to the frame at a maximum of 450mm (18”) centres and bolted through the floorpan to a steel plate of equal size. The floor frame if fitted may be directly connected to the front sub-frame or any framework supporting the engine, gearbox or front suspension.
- c). The floor frame if fitted may be directly connected / attached to the front sub-frame or any framework supporting the engine, gearbox or front and/or rear suspension. The method of connection/attachment must be secure and fit for purpose.

Note.

- i). The construction of a complete steel tube “Rolling chassis space-frame” and the secure attachment of a body-shell is permitted.
The floor frame and roll cage and chassis space frame must be an integral part of the whole vehicle and bodyshell construction. See Fig 1i.
- ii). For a non-original replacement panel floorpan used in conjunction with a floor frame, the floorpan must be constructed of a single sheet steel so as to comply with Rule 2.9 and welded to the vehicle bodyshell such that the floorpan is below the bottom face of the floor-frame construction steel tubes and/or bars. See Fig 1h.
- iv). The creation of a floor-frame and floorpan by the infilling of voids between the floor-frame construction tube/bars with welded or bolted or riveted infill sheets or panels is prohibited.

2.13 Bumpers.

a). Front Bumper:

- i). For all vehicles except for Leyland/Rover Mini & Metro, Hillman/Chrysler Imp, Fiat 126, Fiesta Mk 1 & Mk 2, and Suzuki Sc100 bodyshell based types a front bumper must be fitted. (i.e. Leyland/Rover Mini & Metro, Hillman/Chrysler Imp, Fiat 126, Fiesta Mk 1 & Mk 2, and Suzuki Sc100 vehicles front bumpers are not mandatory).
- ii). The original standard production automotive plastic vehicle bumper may be interchanged with that of another vehicle, provided the vehicle bumpers are so similar as to be considered identical, and the vehicle silhouette is not affected.
- iii). Where a bumper is part of a wheel arch, the bumper sides and/or edges may be partially cut and/or trimmed and removed to suit the size & diameter of wheel & tyre assembly used. (See Rule 2.7, 2.15 & 2.16). Also Saloons General Rule 2.16.

b). Rear Bumper:

Standard production original rear bumpers may be retained or removed. (See Saloons General Rule 2.13).

- i). The original standard production automotive plastic vehicle bumper may be interchanged with that of another vehicle, provided the vehicle bumpers are so similar as to be considered identical, and the vehicle silhouette is not affected.
- ii). Where a bumper is part of a wheel arch, the bumper sides and/or edges may be partially cut and/or trimmed and removed to suit the size & diameter of wheel & tyre assembly used.

Note.

- i. If the rear bumper is removed, then the remaining aperture must be filled in as Saloons General Rule 2.16.
- ii. For vehicles fitted with synthetic and or automotive plastic rear bumper it is permitted to remove and or 'trim' the rear bumper and panel behind the bumper below an imaginary line from the top surface of the nearside rear tyre across the rear of the vehicle to the top surface of the offside rear tyre. The tyre top datum point to be adhered to at all times. See Fig. 31.

2.14 Rear Hatchback/Tailgate/Estate Rear Doors.

The Rear Hatchback/Tailgate/Estate Rear Doors must be retained.
Removal or "skinning" of strengthening braces/ribs permitted.
Tailgate hinges may be retained or removed.

For Glazed Tailgate vehicles only.

Where the original vehicle is fitted with a tailgate that is 100% automotive glass then the glass must be removed and 2 diagonal steel bracing bars must then also be fitted in the original bodyshell hatchback/tailgate aperture. The brace bars must be a minimum size of 20mm (3/4") box or 25mm (1") diameter circular tube of a minimum thickness of 16 gauge (1.62mm).

2.15 Wheel Arches.

Front and rear wheel arches may be altered to facilitate wheel widening.

The wheel arch/spat must be fitted below the top surface and not protrude above the top surface of the particular wing they are fitted to. The wheel arch must not encroach into the main "A" post nor "B" post or drivers compartment doors of the bodyshell. Excessive removal of material prohibited. See Rule 2.15. Also See Fig.6 & Fig 17.

Wheel arch support bar/lip.

A steel wheel arch may be fitted with a NASA permitted support bar or lip/edge/border.

If a bar it must be metal and be no greater than 8mm in diameter.

The above may edge the wheel arch rim only. It is not permitted to form a reinforcement linking with any non-wheel arch vehicle body panel/bumper or vehicle roll cage/floor frame/space frame/protection bars.

NASA reserves the right via an appointed Official and or Scrutineer to reject a wheel arch support/lip construction as being unsuitable for the vehicle concerned.

2.16 Wheel Arch/Spat size.

A wheel arch/spat must cover/shield a minimum of the upper surface of the top quadrant (25%) of the wheel and tyre assembly such that each wheel and tyre assembly does not protrude more than 20mm (3/4") beyond the vehicle body line. A wheel arch must not encroach into the main "A" post nor "B" post or drivers compartment doors of the bodyshell.

Note.

The "body line" includes the actual wheel arches/spats.

The fitting of "air holes" in wheel arches/spats is prohibited.

Failure to ensure that the wheel arch covering remains fitted during racing is a Black Flag (Race Disqualification) offence.

2.17 Side Skirts.

Where a vehicle is fitted with modified wheel arches or spats that protrude from the bodyshell or wing more than the original fitted standard wheel arches, then the fitting of a "Side skirt" from the nearside and offside of the vehicle is permitted. The use of an "Enclosed base or bottom" type "Side skirt" is prohibited.

The "Side skirt" shall be fitted so as to join the bottom rear edge of the front wheel arch with the bottom front edge of the rear wheel arch in a horizontal line (Angled "Side skirts" are prohibited) The side skirt must be constructed of a maximum of 20 gauge steel or aluminium sheet.

The use of proprietary manufactured "Non-enclosed base or bottom" type "Hot Rod" type side skirts is permitted.

The "Side skirt" may be supported along its horizontal length via a maximum of 3 No. 25mm wide strips of 20-gauge steel or aluminium sheet fitted between the lower edge of the bodyshell and the lower edge of the "Side skirt".

It is prohibited to reinforce the outside edge of the "Side skirt" with any material, i.e. Additional metal sheeting. Double skinning, solid or round or box section tubing, wood, glass-fibre, Kevlar, automotive plastic, carbon fibre.

Due to the different types of vehicles that may have side skirts fitted, the "Side skirt" must not protrude more than whichever is the smaller dimension or distance of the following:

- i. More than 100mm (4") from the vehicle bodyshell.
- ii. Beyond an imaginary line joining the outside edge of the front wheel arch with the outside edge of the rear wheel arch.

2.18 Wheelbase.

The vehicle wheelbase is free. See Rule 2.15.

The wheels must remain within the vehicle silhouette, when viewed from the side.

2.19 Vehicle Track The track is free.2.20 Pick-up vehicles only.

i. The rear pick-up bed sides and rear must remain as standard production silhouette, sizes and dimensions for its whole length. i.e. it must not be reduced and or shortened either in height, length, or width. See Fig 35.

Replacement door skin and rear bed side panels must be separate panels. "One piece" combined replacement panel prohibited.

ii. Engine located to rear of vehicle "Cab".

For rear engined vehicles the engine, including carburettors/throttle bodies, but excluding air filter(s), should be fully within the silhouette of the vehicle. i.e. When viewed from the side the engine(s) must be within the triangular area bounded by the rear facing brace bars and must be within the pick up bed sides. See Fig. 30.

It is permitted for the carburettors/throttle bodies to slightly protrude above the pick-up bed sides provided a raised protection bar(s) is/are mounted to the chassis to provide protection for the carburettors/throttle bodies. The carburettors/throttle bodies and all protection bar must be within a 150mm maximum height limit. See Fig. 30.

2.21 Pick-up vehicles only.

For Front Engined Vehicles only.

If the original driver's compartment to rear pick up bed bulkhead has been removed, to protect the driver in the event of an accident, an additional safety bar MUST be fitted from the junction point of the top roll bar above the driver, with the rear upright nearest to the driver to the junction point of the rear brace bar and rear cross bar on the opposite side of the vehicle. (See Fig.19). The additional bar must comply with specified measurements as for roll bars.

For rear/mid engine vehicles the safety bar is not required.

2.22 Air cooling holes:

Where a radiator has been fitted to the rear of the driver's compartment (Or in the rear boot/luggage/engine compartment) to allow the exit of air from the rear of the vehicle a maximum of 4 in number 50mm (2") diameter holes may be cut in the rear panel or rear half of the rear boot/rear luggage compartment lid or rear engine cover/rear bonnet only.

Note:

i. It is NOT permitted to cut or form additional air cooling or air inlet/exit holes to supplement the existing front or other grilles etc; in any panel/area/wheel arch etc; of the vehicle.

ii. If the radiator is retained within the original vehicle engine compartment it is NOT permitted to cut or form air cooling or air inlet/exit holes in any part/area etc; of the vehicle.

3 WINDSCREEN & GLASS – As Saloons General.

4 STEERING

4.1 Steering System.

The steering system & drive from the steering wheel to front wheels is free.

Open "Chain and or gear drives" must be fitted with chain & sprocket / gear guards.

"Steering arms" must be of metal.

NASA reserves the right via an appointed Official and or Scrutineer to reject steering components as being unsuitable for the vehicle concerned.

Power Steering.

Permitted.

4.2 Steering Column.

Steering column location free.

The steering column if fitted other than by the original vehicle manufacturer must be attached to:

Either: A support bar of roll cage specification, which is attached to the front roll cage uprights, between each upright, across the front of the driver's compartment in the dashboard area.

Or: A support bar or supporting steel tubing frame constructed of a maximum of 25mm x 25mm box or 25mm circular tubing fixed to the bodyshell in the dashboard area.

The support bars must not hinder driver or medical personnel access and egress to driver compartment.

4.3 Steering wheel mounted controls permitted.

Note.

Such systems must not impede, entangle, unlock, unfasten, disengage nor prevent the correct reach and or access to and or operation of any safety harness or other driver operated vehicle controls (e.g. Steering. Ignition switch. Cut off switch. etc.).

5 SAFETY HARNESS – As Saloons General.

6 SEAT

6.1 Seat Location – Central Seating.

Central seating is permitted.

If any part of the driver's seat encroaches into the front passenger's seat area i.e. crosses the centreline of the vehicle, then it is deemed as being "centrally located".

7 FIRE EXTINGUISHER – As Saloons General.

8 IDENTIFICATION – As Saloons General.

9 ELECTRICAL / INSTRUMENTS

9.1 Vehicle Wiring System.

Vehicle electrical wiring system free.

9.2 Electrical Battery.

Type and capacity of electrical battery free. The use of 2 x 12v batteries for 24v starting permitted.

The fitting of multiple or extra large and or commercial and or agricultural vehicle batteries and/or battery containers may be construed as ballast.

9.3 Battery Enclosure & Location – Restricted.

The enclosure box/container maximum size = 300mm Height x 300mm Width x 600mm Length.
Maximum wall thickness = 3mm.

For Front Engined Vehicles.

The enclosure box/container must not be fitted anywhere on the vehicle at a point that is forward of an imaginary line, across the vehicle from the most forward part of either the engine block or gearbox casing including clutch housing.

For Mid/Rear Engined Vehicles.

The enclosure box/container must not be fitted anywhere on the vehicle at a point that is forward of an imaginary line, across the vehicle from the front of the nearside front tyre to the front of the offside front tyre.

9.4 Starting system. - Type free.

9.5 Instrumentation & Gauges. - Free

10 FUEL

10.1 Carburettor(s), Fuel Injection system and Air Filter(s).

Fuel Delivery system free.

Air filter(s) free. However all must remain within the engine compartment and be within the vehicle silhouette.

10.2 Inlet manifold.

Type free.

However the manifold must remain within the engine compartment.

10.3 Fuel Pump.

Fuel pump type and capacity free.

10.4 Fuel Regulator.

Fuel regulator type and capacity free.

10.5 Accelerator.

A single "Accelerator" or "Throttle" pedal, including an "Accelerator/throttle cable" must be fitted to control the operation of the fuel delivery system to the engine

Accelerator type free.

Accelerator cable type free.

10.6 Fuel Tank Location – Restricted.

The fuel tank or "Fuel cell" must not be fitted anywhere on the vehicle at a point that is:

a). Front Engine Vehicles.

Forward of an imaginary line, across the vehicle from the most forward part of the engine block.

b). Mid/Rear Engine Vehicles.

Forward of an imaginary line, across the vehicle from the centre of the nearside front tyre to the centre of the offside front tyre.

11 COOLING SYSTEMS

11.1 Cooling System. - Free.

11.2 Sealed Systems.

When sealed radiator systems are used, they must be of a permitted manufactured type, and be fitted with an approved pressure relief device, in good working order.

11.3 Radiator - Restricted.

Original standard production water cooling radiator may be retained, modified or replaced.

The use of an aftermarket and/or specialist fabricated radiator is permitted. Alloy and or composite metal & plastic radiator permitted.

Number and type of radiators and coolers are free. However they must be fitted within the vehicle silhouette.

Oversize radiators/coolers may be regarded as ballast and prohibited. Commercial vehicle radiator(s) prohibited.

Water/Oil Cooling Radiator Location – Restricted.

The cooling radiators must be fitted within the vehicle silhouette.

The fitting of cooling radiators next to or at the side of or within window apertures prohibited.

Radiator Cooling Fan.

Free.

All electric fan assemblies must remain within the vehicle silhouette.

11.4 Secondary Expansion Tank.

A secondary water-cooling system expansion tank may be fitted. Maximum capacity 1 Litre. See Saloons General - Rule 11.2.

11.5 Water pipes/Hoses.

The standard production water pipes/hoses may be retained or replaced with equal pipes/hoses.

Water pipes/hoses must be of metal or proprietary flexible hose. Silicone hoses permitted.

Type and number of connections free. Type of hose clamps free, however they must be fit for purpose.

11.6 Water Pump. - Free.

11.7 Oil System.

Free.

Oil coolers are permitted.

“Dry sump” and “Accusump” systems permitted.

However it/they must remain within the vehicle silhouette.

Oil tanks.Oil tanks (including catch tank / dry sump tank etc.) must be shielded from the driver in case of spillage in an accident. Oil tanks must not be fitted under the vehicle wings and or anywhere on the vehicle at a point that is:a). **Front Engine Vehicles.**

Forward of an imaginary line, across the vehicle from the most forward part of the engine block.

b). **Mid/Rear Engine Vehicles.**

Forward of an imaginary line, across the vehicle from the centre of the nearside front tyre to the centre of the offside front tyre.

12 BRAKES

12.1 Vehicle braking system type is free. (For Handbrake See Rule 12.4).

Note:

Whilst racing the braking system may be subject to severe stress, pressure and/or heat loading. This must be borne in mind during brake and brake component choices.

NASA reserves the right via a Scrutineer to reject a component choice due to size and ability and or capacity to provide the necessary braking force.

12.2 A brake device (Calliper & disc or shoe & drum) must be fitted on each wheel hub and or wheel hub drive shaft and be kept in good working order at all times.

A brake calliper may be fitted such that it is either “Inboard” or “Outboard”.

Note.

The use of “Kart” and or “Bicycle” brake disc and or brake calliper is prohibited.

12.3 The brake device fitted on each axle hub or wheel hub drive shaft of an axle must be equal in type, size and capacity. i.e. If a disc and calliper is fitted to nearside rear hub, or nearside driveshaft then a disc and calliper of equal size and capacity must be fitted on the offside rear hub or offside drive shaft. See Fig. 23.

12.4 **Handbrake - Restricted.**

Handbrake/Parking brake type and method of operation restricted. The original vehicle handbrake/parking brake may be retained or removed. A handbrake/parking brake may be fitted. If fitted a handbrake/parking brake must operate the rear wheel braking system only. Hydraulic handbrake permitted. Electric handbrake prohibited.

Note.

For vehicles fitted with “Automatic” Transmission electrical “parking” brake permitted.

12.5 **Brake proportioning - Restricted.**

The fitting and use of a brake system proportioning “Brake Balance Bar” and or brake proportioning valve and associated adjustment mechanisms (including lever or handle) is permitted.

The fitting of a brake fluid shut off or isolation tap to facilitate the isolation or deactivation of any part of the braking system is prohibited.

13 WHEELS

13.1 Type, width and diameter of road wheel is free.

- i. Modification of a proprietary manufactured wheel other than machining to suit “Beadlock” conversion is prohibited.
- ii. Beadlock type wheels may be used but the “Beadlock rim” fixing bolts must have either “Button head” or “Countersunk head” bolts only. Hexagon head “Beadlock rim” fixing bolts prohibited. The fixings must not protrude beyond wheel rim. Beadlock wheels must be complete with all rim fixing bolts.
- iii. Maximum permitted wheel diameter is 17”.

13.2 **Wheel Spacers – Type restricted.**

- i. The fitting of wheel spacers is permitted.
- ii. A wheel spacer must be of proprietary manufacture, be of solid uniform one piece that incorporates an integral backing plate.
- iii. The alteration of or thinning or machining of proprietary wheel spacers is prohibited.
- iv. The associated wheel studs must be of a one-piece type and of correct size. “Extension studs” prohibited

13.3 **Wheel Adaptors. – Type restricted.**

The use of wheel adaptors to fit wheels of a different PCD is permitted.

The use of wheel spacers and/or combined wheel spacer and wheel adaptor permitted.

Note.

Whilst racing, a wheel adaptor/spacer may be subject to severe shock and stress loading. Adaptor/spacer type and construction and fixings must be suitable and fit for purpose for the shock and stress loadings of the “Autograss racing environment”. This must be borne in mind during adaptor/spacer choices.

NASA reserves the right via an appointed Official and or Scrutineer to reject a adaptor/spacer, deemed as not fit for purpose and unsuitable for the shock and stress loadings of the “Autograss racing environment”.

14 TYRES14.1 **Tyre Width - Restricted.**

Maximum permitted tyre width is 225.

15 EXHAUST**15.1 Exhaust System**

Exhaust manifold and system are free. See Saloons General - Rule 15.2.
The exhaust manifold and system must be fitted within the vehicle silhouette.

- 15.2 The single engine exhaust system outlet or outlets must end at the rear bodyline of the vehicle, and not protrude beyond 50mm of the vehicle bodyline.
It is recommended that the outlet end be at a point between the rear of the "B" pillar and the rear of the vehicle.
The outlet or outlets must be at a point that is easily accessible for the taking of noise level test measurement readings.
All outlets of multiple exhaust systems must terminate at a single common point, enclosed within an imaginary area of 300mm diameter. See Fig. 26.

Note.

- i. The outlet pipe or pipes must point either horizontal or downward at an angle of not more than 30° (degrees) from the horizontal.
 - ii. For rear engined 'pick up' type vehicles.
Where the exhaust outlet or outlets is/are at a height above the side of the rear pick up bed, then the outlet or outlets must point downward, at an angle of not more than 30° (degrees) from the horizontal.
- 15.3 The engine(s) exhaust systems outlet or outlets must end at the rear bodyline of the vehicle, and not protrude beyond 50mm of the vehicle bodyline.
It is recommended that the outlet end be at a point between the rear of the "B" pillar and the rear of the vehicle.
The outlet or outlets must be at a point that is easily accessible for the taking of noise level test measurement readings.
All outlets of multiple exhaust systems must terminate at a single common point, enclosed within an imaginary area of 300mm diameter. See Fig. 26.
- Note.
- i. The outlet pipe or pipes must point either horizontal or downward at an angle of not more than 30° from the horizontal.
 - ii. For pick up' type vehicles.
Where the exhaust outlet or outlets is/are at a height above the side of the rear pick up bed, then the outlet or outlets must point downward, at an angle of not more than 30° (degrees) from the horizontal.
- 15.4 Exhaust Route - Front Engine Vehicles.
The exhaust may pass from the engine compartment to the driver's compartment, through the front bulkhead at low level, however the top surface of the exhaust pipe must be no greater than 300mm from the vehicle floor level when measured at the lower bulkhead/floorpan panel angle. (See Fig. 12).

16 SAFETY SHIELDS**16.1 Engine Fire Shield (Bulkhead).**

All vehicles must be fitted with a securely fitted full width metal fire shield (Bulkhead) between the driver and the engine/transmission unit, ancillaries and cooling radiators.

a). For a front engined vehicle.

The shield (Bulkhead) must be installed from the vehicle floorpan to a height equal to the whole bottom surface of the front windscreen aperture and formed to suit the curvature etc; and from the nearside inside surface of the bodyshell to the offside inside surface of the bodyshell, without any gaps, all as necessary to protect the driver. See Fig. 29.

b). For a rear engined vehicle.

If an imaginary person was to occupy the driver's seat and rotate an imaginary 180 degrees, then no part of the engine/transmission unit should be visible.

The shield must be installed from the vehicle floorpan to a height equal to the top of surface of the engine or engines' "Rocker or cam cover", then rising and tapering up to a point on the roll cage rear hoop above the centre of the driver's seat. See Fig 26.

16.2 Belhousing/Gearbox & Prop Shaft.

Where prop-shafts, gearboxes and bell-housings are mounted within the drivers compartment area and are not contained in the original vehicle's engine compartment to drivers compartment bulkhead and/or transmission tunnel(s), they must be covered with metal (Steel: 16 gauge (1.62mm) Non steel 1/8"(3.2mm) minimum thickness) sufficient to act as a safety shield. No mechanical component shall be visible or accessible from the interior and/or inside of the bodyshell. The use of pop rivets as mechanical fixings is prohibited.

- 16.3 All transmission/drive chains must be suitably encased by a substantial material, minimum 2mm steel sheet, to contain the chain in the event of breakage.

- 16.4 Where transverse mounted engine installation is used, then the following metal fire & safety shields must be securely fitted.

i. For front and rear engined vehicles - Flywheel shield.

Fitted to interrupt an imaginary line between the vehicle driver and engine or engines flywheel.

The shield to be no more than 100mm from the flywheel bell-housing/enclosure.

The shield to be constructed from steel plate, minimum 6mm (1/4in), thickness 460mm (18ins) high, 100mm (4ins) width.

ii. For rear engined vehicles.

From the vehicle floorpan to a height equal to the top of surface of the engine or engines 'rocker or cam cover' and from the roll cage upright adjacent to the driver' seat to a point beyond the width of the driver's seat so as to completely shield the driver from the engine or engines. (See Fig. 27.)

The shield to be constructed from either: Steel sheet minimum 2mm thickness or Aluminium sheet minimum 3mm thickness.

- 16.5 Sump Guard Shape/Dimensions - Restricted.
There shall be no vertical surface extending above the base of the vehicle chassis or the suspension cradle.
The sump guard may be extended to provide gearbox protection.
The sump guard area shall not be extended to incorporate suspension system and/or suspension component mounting and or mounting protection.
- 16.6 Exhaust Shield.
Exhaust pipes, when fitted inside the driver's compartment, must be covered with material sufficient to act as a safety shield.
- 16.7 Suspension Shield.
Shock absorbers, springs or coil/shock absorber assemblies and or "link" bars/arms located adjacent to the driver's compartment must be shielded from the driver. The shield is to be made of either steel or aluminium sheet a minimum of 2mm thickness.

17 SUSPENSION

- 17.1 Suspension Type – restricted.
Any form of passive suspension may be used. (See Fig.15 & 16).
Active /Adaptive/ semi-Active Suspension prohibited.
Suspension components must be of metal.
Track conditions may mean that suspension components and component to chassis mounting points may be subjected to severe stress loadings. This should always be borne in mind during suspension design and component choices.
NASA reserves the right via a Scrutineer to reject a component choice due to size and ability and or capacity to provide the necessary vehicle suspension. Suspension components must be shielded from driver See rule 16.7.
- 17.2 Suspension mounting points.
Suspension mounting points must be built in a secure manner and be robust and sufficient to withstand race track conditions.
Note.
Where suspension mounting or support bars are fixed to the floorpan and or floor frame, the fixing points must be have a clearance of not less than 150mm distance from any seat or harness fixing point.
- 17.3 Suspension Components.
Suspension unit/damper type, number, material and size/rating – Free.
Suspension arms and wheel hubs must be of metal otherwise - Free.
Suspension bushes – Free.
Suspension spring type, number and rating – Free.
Rose Joints – Free.
- 17.4 Strut Brace.
A "Strut Brace" may be fitted between the engine compartment suspension turret housings.
- 17.5 Wheel Alignment.
Wheel camber, castor and alignment (toe in/out) is free.
- 17.6 Vehicle ride height.
The standard production vehicle ride height may be retained or modified.
No minimum or maximum ride heights will be given.
NASA reserves the right via an appointed Official and or Scrutineer to reject a vehicle ride height (too high or too low) deemed as not fit for purpose to ensure full control of the vehicle and unsuitable for the shock and stress loadings of the "Autograss racing environment"

18 PROTECTION

- 18.1 Rear Protection - Restricted.
Rear Protection as described in Saloons – General Rule 18.3 & 18.4 permitted.
Note.
a). No more than 2 brace bars of maximum size 1" x 1" (25mm x 25mm) box may be used to support the protection bar. (See Fig. 18).
b). The 25mm support bars, (if fitted) may be connected to the rear luggage compartment/boot floor or if the rear luggage compartment/boot floor has been removed must be connected to either: The vehicle floorpan or "component support bar" at a height +/- 50mm of the original vehicle rear boot floor location/position or lower cross member of the "rear suspension frame/cradle" or "mid/rear engine frame/cradle".
c). Where the protection bar(s) are fixed to the outside of the rear panel, the support bars may pass through the rear panel.
d). Protection bar(s) and support bars must not be connected to the roll cage or any brace bar(s).
e). The protection bar or support bar(s) must not be connected to the vehicle rear wheel arches.
f). All support bars to the rear of the rear face of the rear tyres and protection bar must have a wall thickness no greater than 3.5mm.
- 18.2 For Rear engined vehicles local rear gearbox and rear engine ancillary protection is permitted as an addition to the 'Engine/Gearbox/Suspension cradle' and must comply with the sizes indicated in Saloons General – Rule 18.3.
Engine/Gearbox/Suspension Cradle and protection bar construction must be fit for purpose. Excessive construction is regarded as ballast/reinforcement and prohibited.
- 18.3 Distributor Protection
Front transverse engined vehicles only. Restricted to local distributor area. One 1" x 1" (25mm x 25mm) box section maximum, top bolted to engine, bottom to sub-frame/lower chassis/engine cradle member.

19 BALLAST

- 19.1 The use of specified “Ballast” is permitted.
Ballast must be as specified. Other forms of “Ballast” are prohibited.

Ballast Location – Restricted.

Ballast must be located at the non-drive part of the vehicle.

For a RWD vehicle it must be fitted adjacent to the vehicle front between the foot pedals and most forward part of suspension cradle.

For a FWD vehicle it must be fitted adjacent to the vehicle rear between the rear floor bar and most rearward part of suspension cradle.

- 19.2 Ballast Construction.

Ballast shall be constructed of steel and be in “Plate” form to the following dimensions.

Overall size limit maximum = 200mm L x 150mm W x 75mm Total Thickness.

Ballast may be removable and or adjustable.

Adjustment shall be by means of the use of individual steel plates.

The maximum thickness of any individual plate is 10mm thickness. i.e. the number of individual ballast plates is free subject to the maximum total overall thickness of 75mm.

Maximum weight of ballast = 15 Kg.

- 19.3 Ballast Fixing/Mounting.

The ballast must be securely fixed to a ballast mounting base plate and be held down by a ballast top plate.

The ballast mounting base plate and ballast top plate must be constructed of steel and be 200mm L x 150mm W with a minimum thickness of 10mm and a maximum of 14mm thickness.

The ballast mounting plate must be fixed (Bolted/welded) to the vehicle chassis. It is not permitted to be fixed to vehicle floor or panelling/bodyshell.

If bolted then a minimum of 4 No 10mm Diameter HTS (minimum grade 8.8) must be used. If welded there shall be a minimum of 4 x 25mm stitch welds.

The individual ballast plates must be fixed to the mounting base plate and held in place by a ballast top plate by means of a minimum of 2 No. 12mm Diameter HTS (minimum grade 8.8) bolts & full nuts (Type - Plain with spring washer or Nyloc). A minimum of 10mm thread must protrude from the top of the Ballast top plate at all times. See Fig. 28.

20 CHECK SHEETPERMITTED AND PROHIBITED VEHICLES.

The lists of permitted and prohibited vehicles are not fixed.

NASA reserves the right via an appointed Official and or Scrutineer to permit, reject and or prohibit a vehicle/bodyshell as being suitable or unsuitable for Class 7 Autograss racing at any time.

PERMITTED VEHICLES.

Class 7 Rules and Regulations type compliant.

PROHIBITED VEHICLES.General Description Type.

Any vehicle that has a chassis that is not integral (Monocoque) with the bodyshell including following examples of non-permitted vehicles:

Station Wagon models.

“Sports” car/Cabriolet/Convertible models.

2 door “Coupe” models.

4WD models.

Non-specified “Estate” and or Dual Purpose (Pick Up) models of vehicle.

Vans

Specific vehicles.

Audi TT.

Austin A40 Farina. A30. A35. Allegro Estate.

Ford Popular/Prefect/Anglia 100e/101e/107e.

Morris Minor. Minor 1000.

Triumph - TR7 / Herald / Vittesse models.

Smart Car /Forfour/Roadster (All Models).

Subaru – Justy (4WD).

Fiat - Panda (4WD).

Fiat X19

Jeep

Land Rover, Range Rover, Discovery, Defender, Freelander

Shogun

Vauxhall Tigra.

PROHIBITED ENGINES.

Engines to Class 1, 2, 4 and 5 specifications.

"Motorbike", "Motorcycle" "Motorbike Type" and or "Motorbike/cycle conjoined" engines that have Forced Induction (Superchargers/Turbochargers).

Note.

The list of prohibited engines is not fixed.

It is the Competitors and/or race vehicle constructor's responsibility to contact a Scrutineer to confirm that the engine chosen is eligible before using it in the vehicle.

NASA reserves the right via an appointed Official and or Scrutineer to permit, reject and or prohibit an engine as being suitable or unsuitable for Class 7 Autograss racing at any time.

FIGURES:

**Figure 1a.i, 1a.ii, & 1b.i, 1b.ii, 1b.iii. - Roll Cage - Original Floor Intact.
As Saloons Section 1. Figs 1a, 1b, 1c, 1d, 1e.**

Figure 1c i. Roll Cage - Original Floor not Intact – Side Elevation.

All Bars - Minimum sizes and specified wall thickness and as Rule 11.

Bar Tb is mandatory.

Bar Fb is optional.

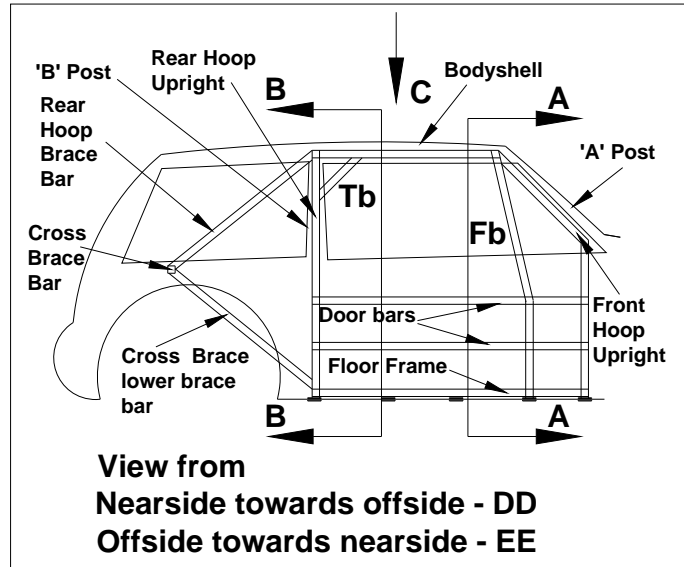

**ORIGINAL VEHICLE FLOOR NOT INTACT
(PART REMOVED AND OR HAS HAD
REPAIRS AND OR REPLACED WITH STEEL
SHEET).**

Gy

Figure 1c ii. Roll Cage - Original Floor not Intact Front & Rear View.

All Bars - Minimum sizes and specified wall thickness and as Rule 11.

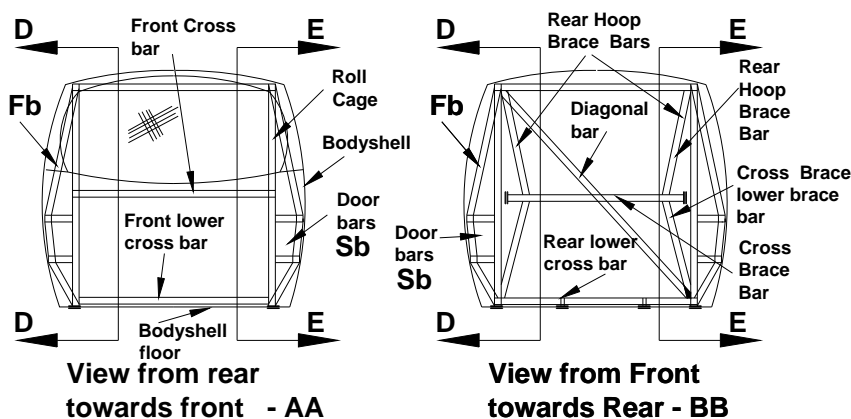

**ORIGINAL VEHICLE FLOOR NOT INTACT
(PART REMOVED AND OR HAS HAD REPAIRS
AND OR REPLACED WITH STEEL SHEET).**

Gy

Figure 1d Roll Cage - Optional Bars – Side Elevation.

All Bars - Minimum sizes and specified wall thickness and as Rule 11.
 Bar Tb is mandatory.
 Bar Fb is optional

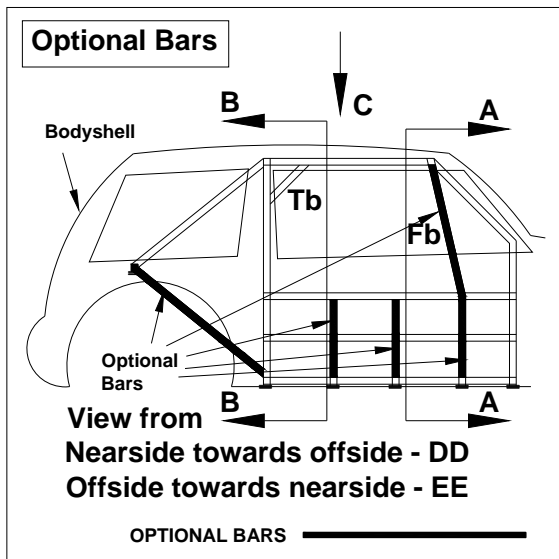

NOTE.
 Some optional bars become mandatory if original vehicle floor not intact - See Fig 1b.

gij

Figure 1e Roll Cage - Optional Bars – Front & Rear View.

All Bars - Minimum sizes and specified wall thickness and as Rule 11.
 Bar Fb is optional

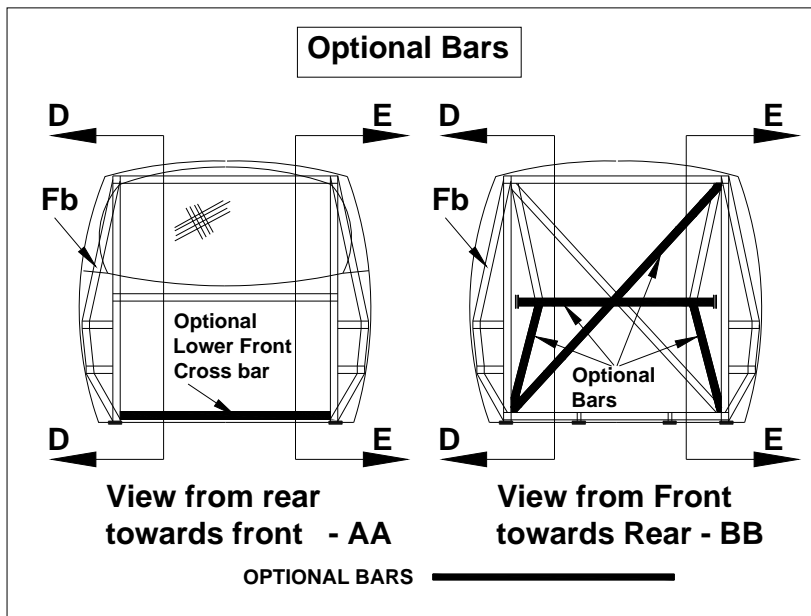

gij

Figure 1f Roll Cage - Optional Bars – Plan View.

All Bars - Minimum sizes and specified wall thickness and as Rule 11.

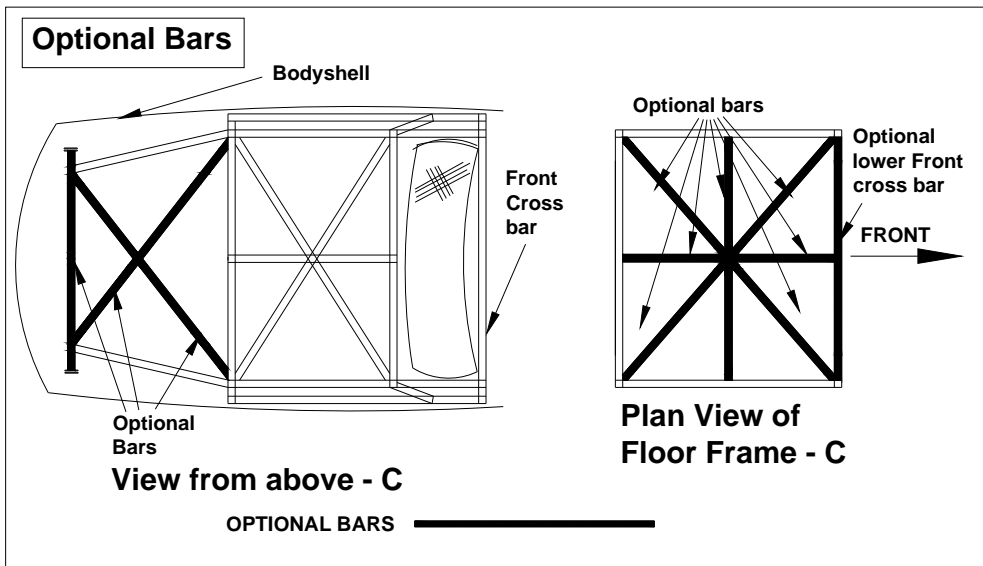

gij

Figure 1g – Floor Bar – Tunnel Options.

All Bars - Minimum sizes and specified wall thickness and as Rule 11 & 16.

Nearside to Offside - Floor bar Tunnel Fitting Options

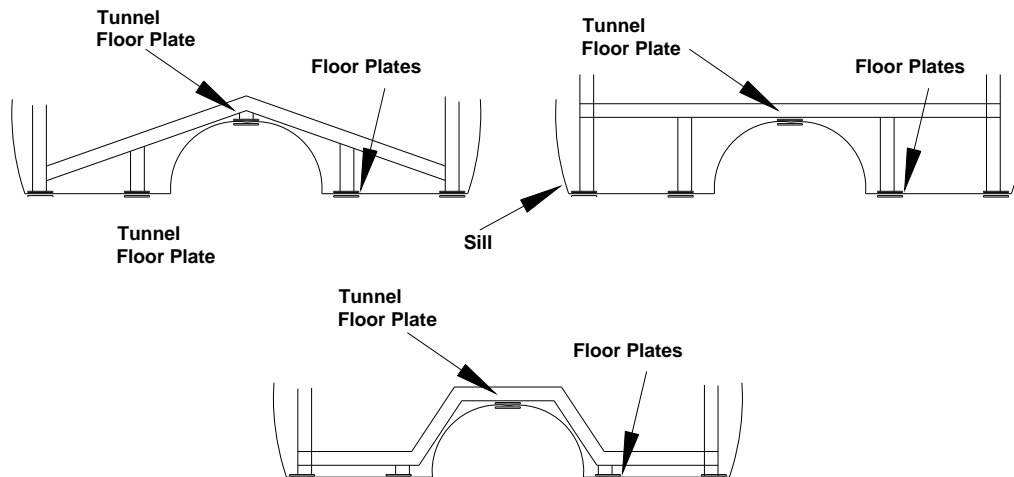

gij

Figure 1h – Floor Frame Location.

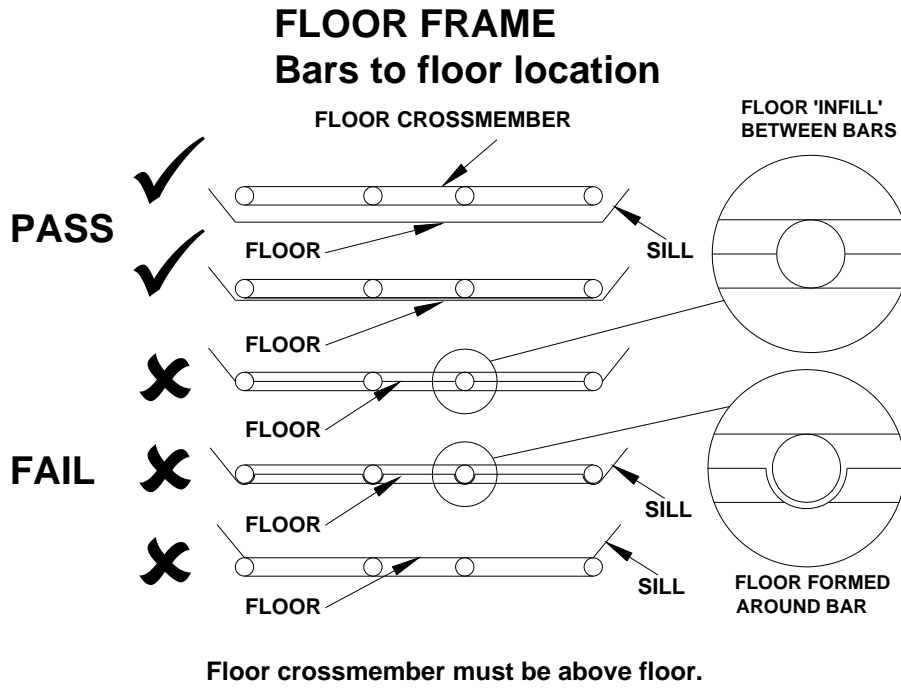

gij

Figure 1i.

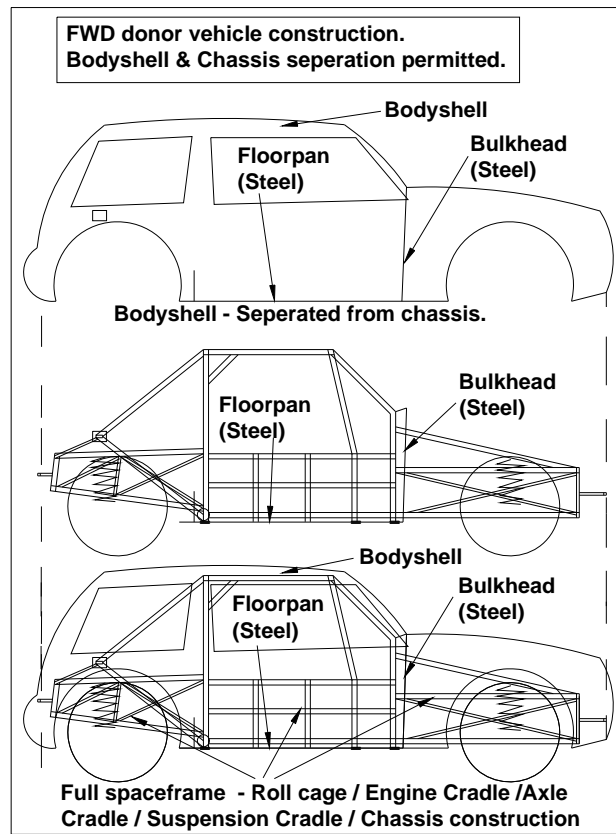

gij

FIGURE 5 INNER FLITCH PANEL REMOVED.

25mm (1") MINIMUM BOX/CIRC SECTION STEEL TUBE.
BOLTED / WELDED FROM FRONT OF SUBFRAME TO THE FRONT BULKHEAD

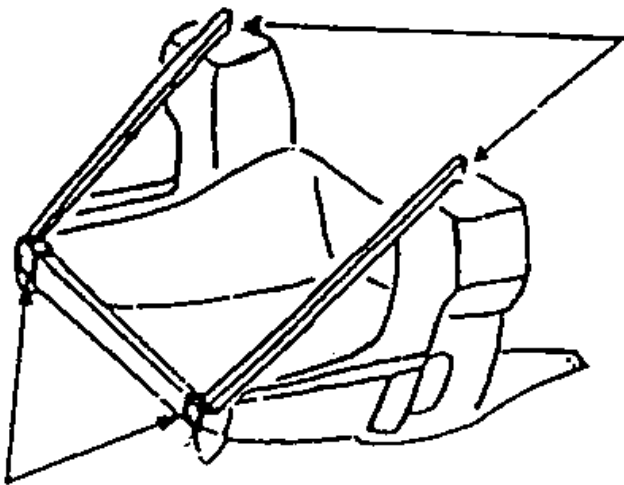

25mm (1") ANGLE SUPPORT

FIGURE 6 VEHICLE WING WHEEL ARCH MODIFICATIONS.

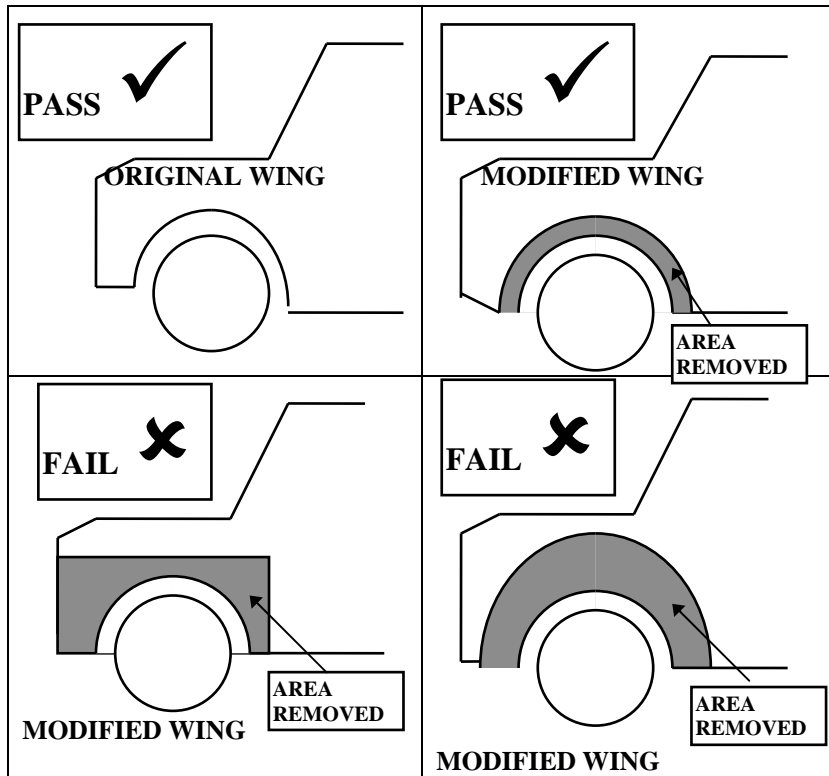

94

FIGURE 7 FLOOR BARS.

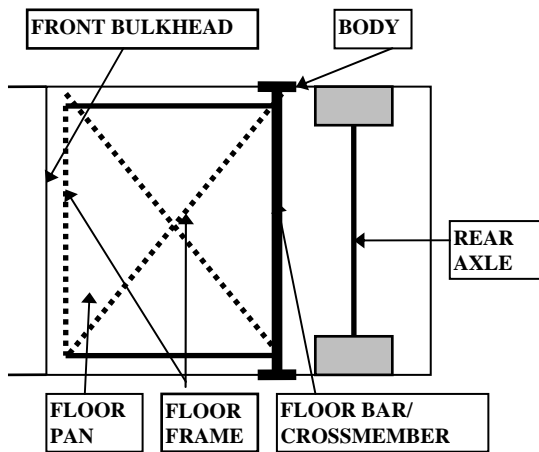

94

FIGURE 8 FLOOR CROSS BAR.

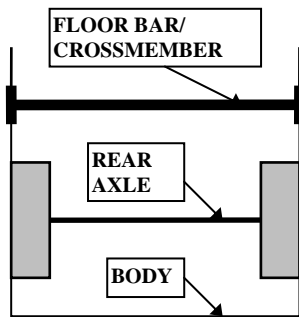

gij

FIGURE 9 CROSS BRACE/MEMBER END PLATES.

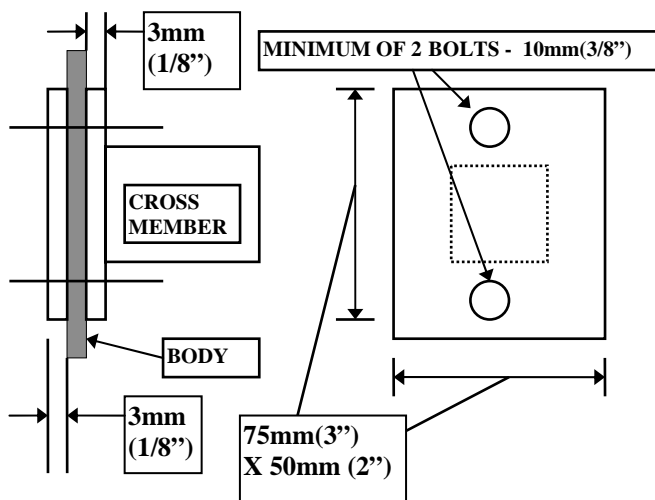

gij

FIGURE 10 SEAT BELT HARNESS SUPPORT BAR.

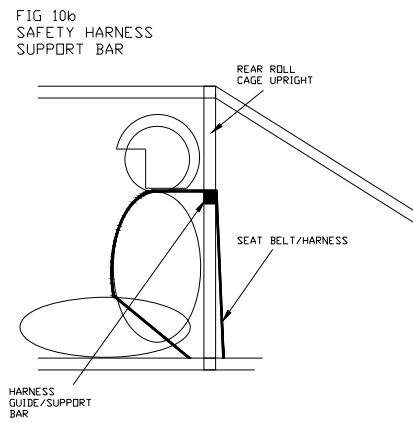

gij

FIGURE 16 TRAILING ARMS.

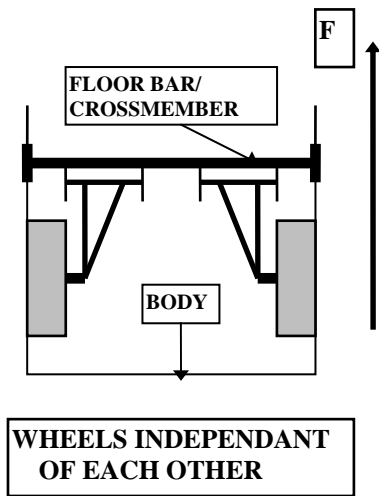

gij

FIGURE 17.
Mini Front Panel – Wheel Arch Trim Limit.

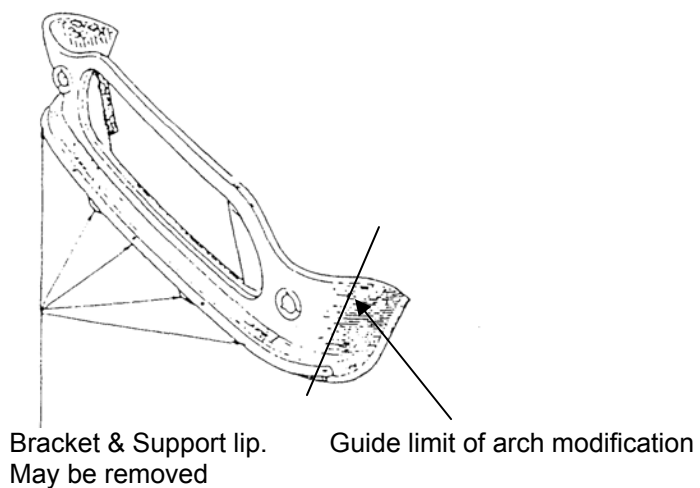

99

FIGURE 18 REAR PROTECTION BAR.

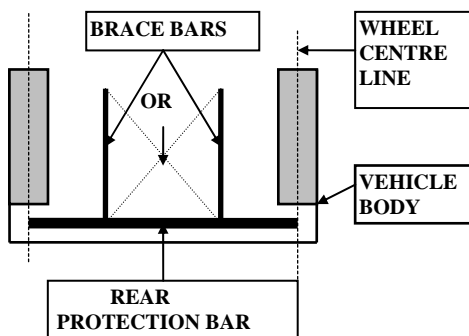

99

FIGURE 19 REAR SAFETY BAR.

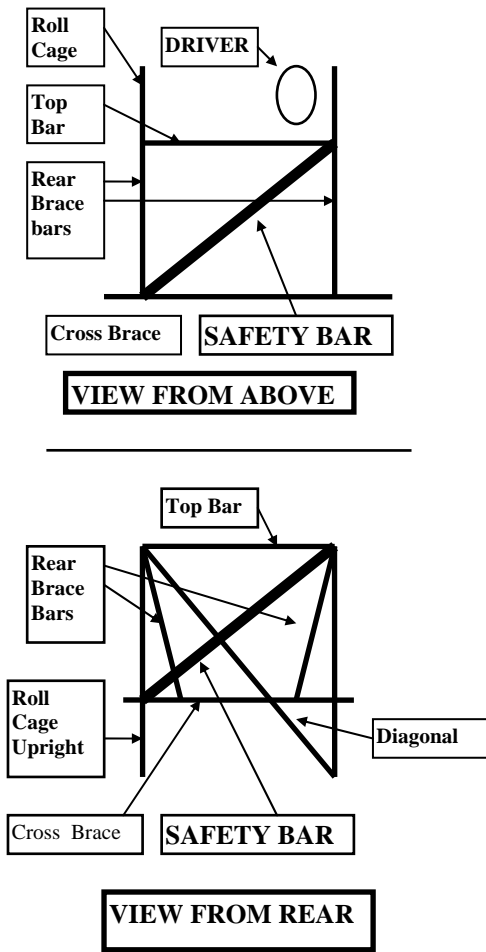

gii

FIGURE 20a ROLL CAGE:
REAR HOOP BRACE BARS ATTACHED TO CROSS BRACE.

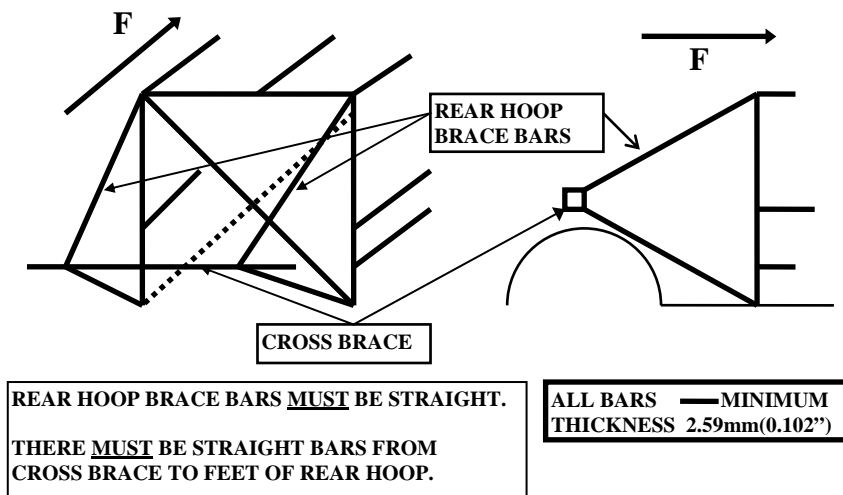

gii

FIGURE 20b ROLL CAGE:
REAR HOOP BRACE BARS NOT ATTACHED TO CROSS BRACE.

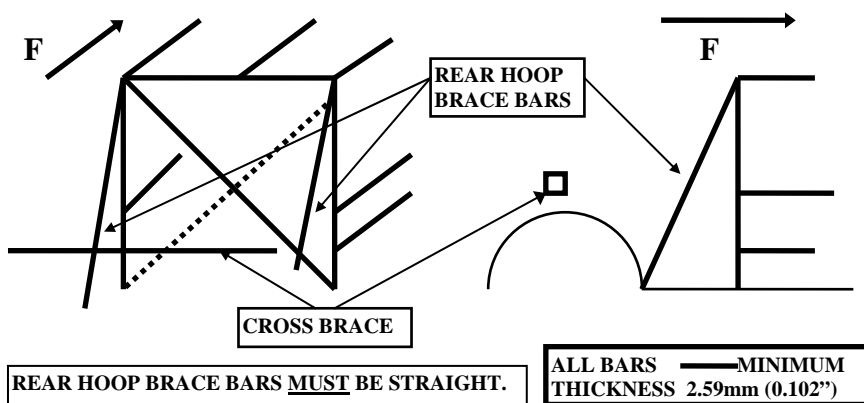

gii

FIGURE 21 PICK UP VEHICLES REAR ROLL CAGE. HOOP EXTERNAL TO CAB.

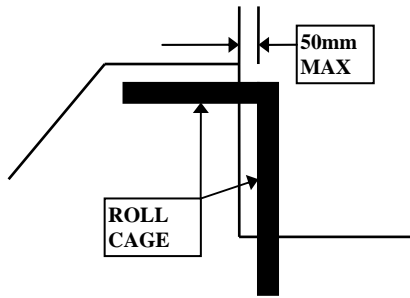

gü

FIGURE 22 PERMITTED FRONT SUSPENSION. STRUT BRACE BAR MOUNTING.

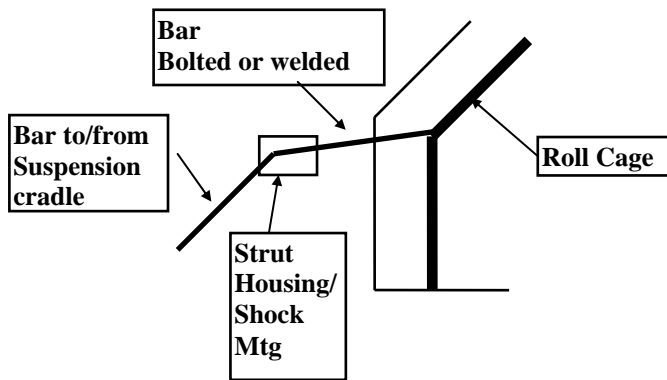

gü

FIGURE 23 – BRAKES.

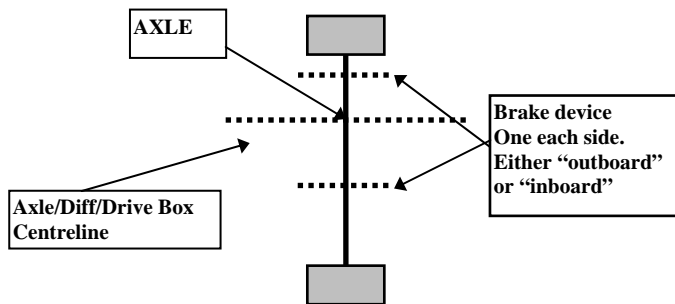

gij

FIGURE 25a FRONT ENGINE VEHICLES - FRONT SUSPENSION / ENGINE CRADLE.

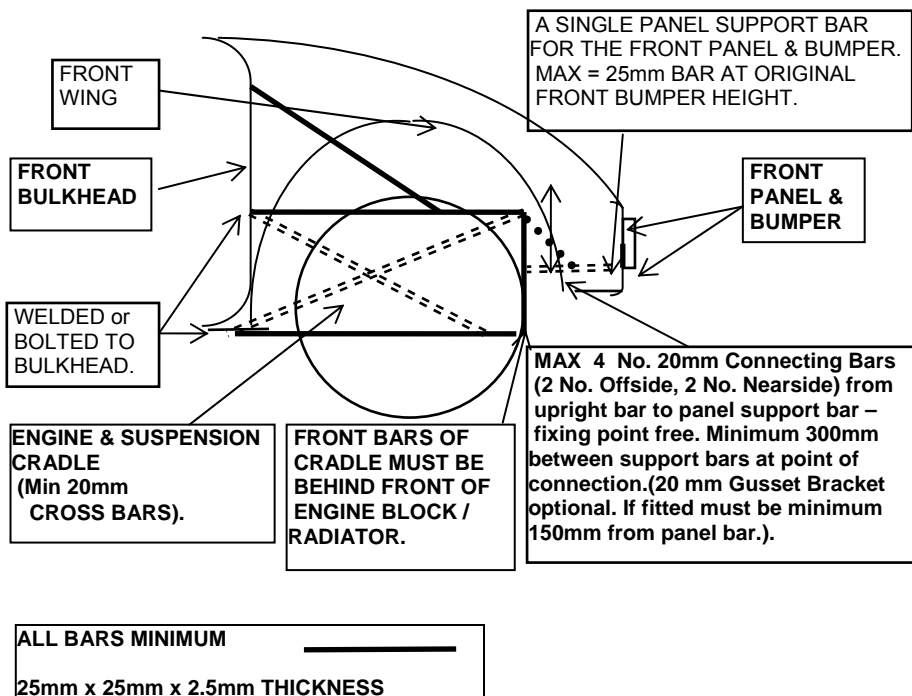

gij

FIGURE 25b REAR/MID ENGINED VEHICLES - FRONT SUSPENSION CRADLE

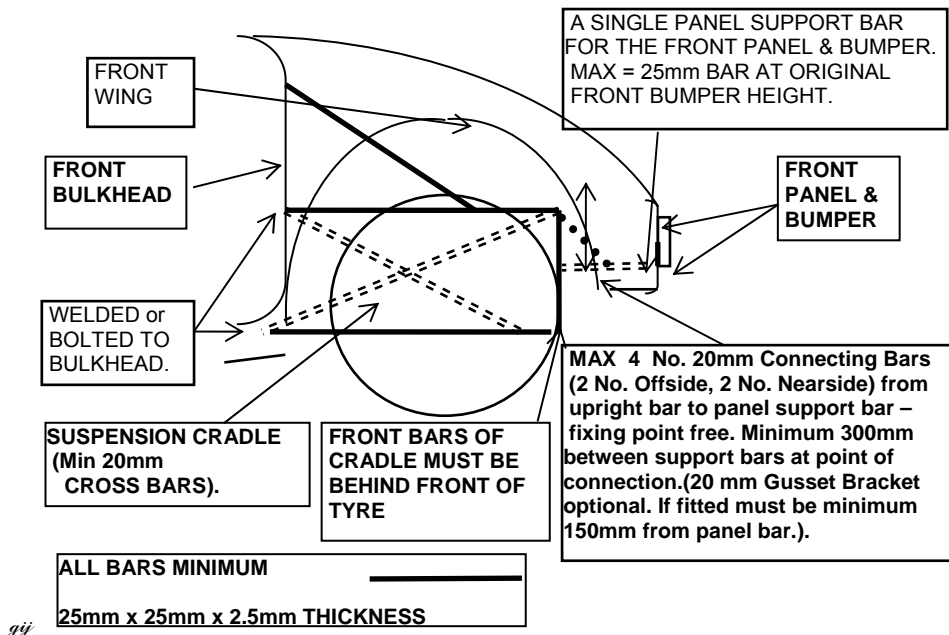

FIGURE 26a TWIN EXHAUST OUTLETS.

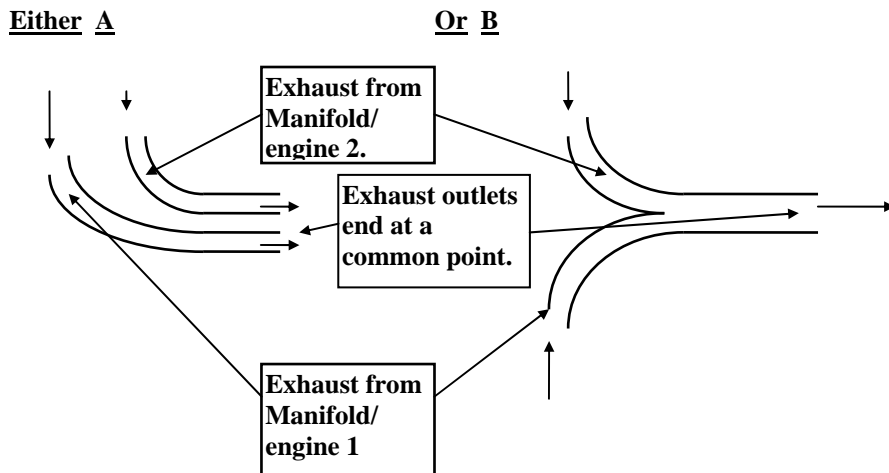

FIGURE 26b TWIN EXHAUST OUTLETS

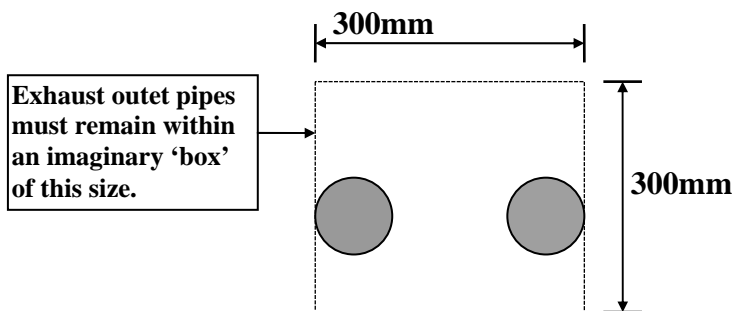
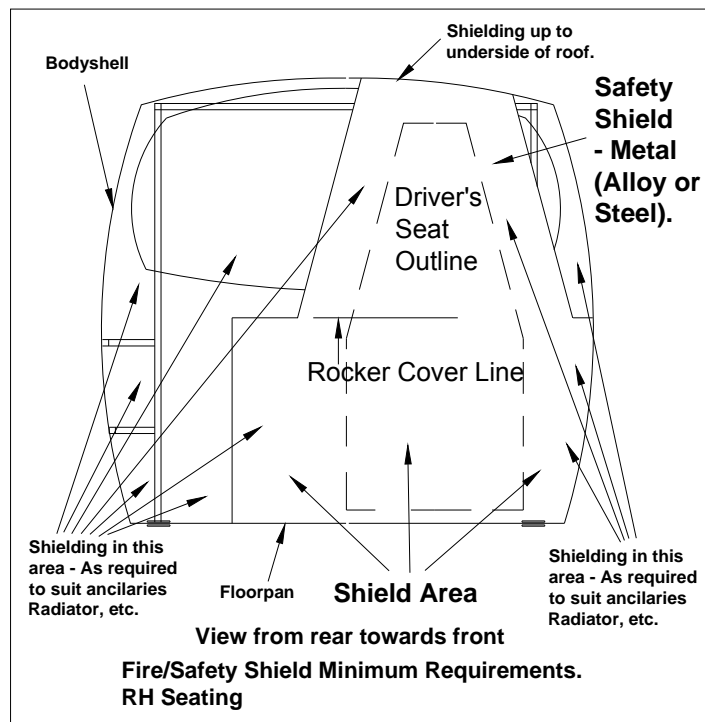
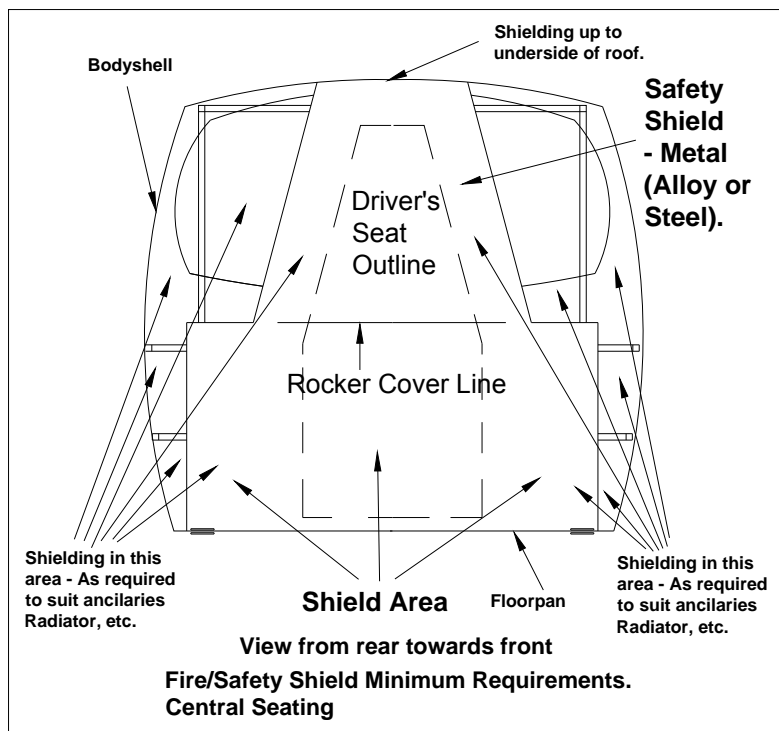

FIGURE 27 ENGINE & ANCILLARY SAFETY SHIELD.
27a.



27b.



gii

FIGURE 28 BALLAST REQUIREMENTS.

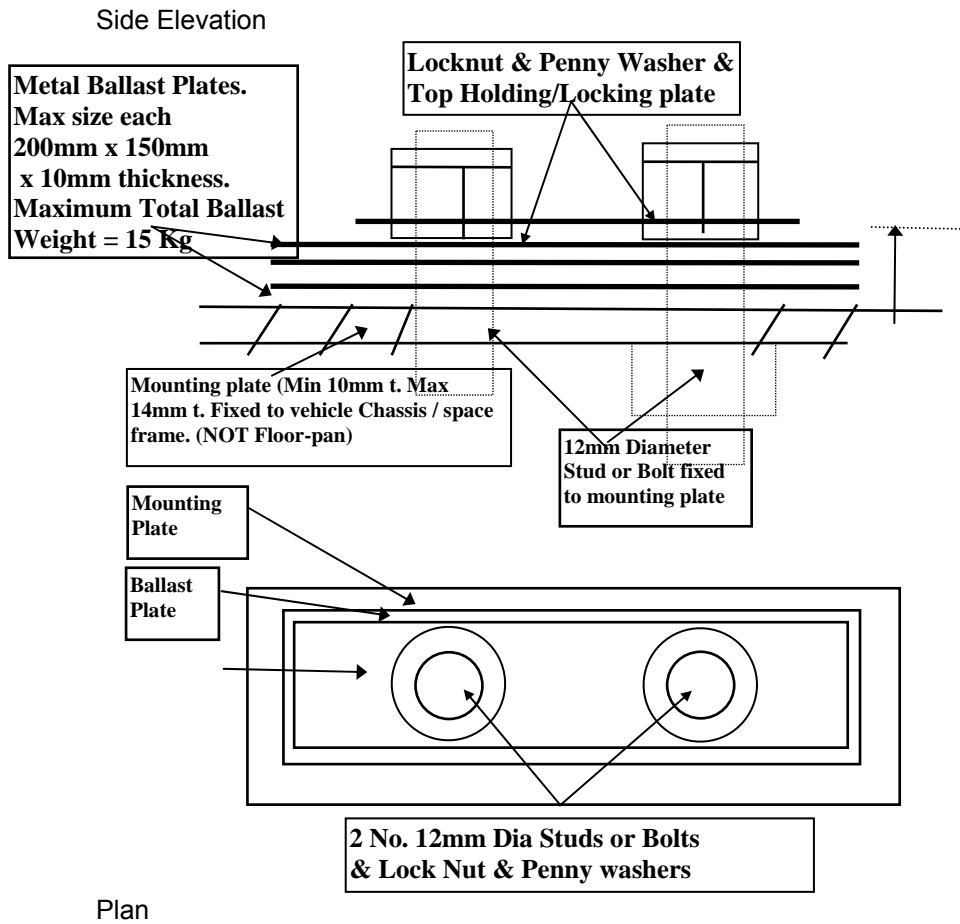

gij

FIGURE 29 BULKHEAD REQUIREMENTS.

N.B.

The bulkhead must fit from inside nearside bodyshell to inside offside bodyshell across the vehicle, without any gaps.

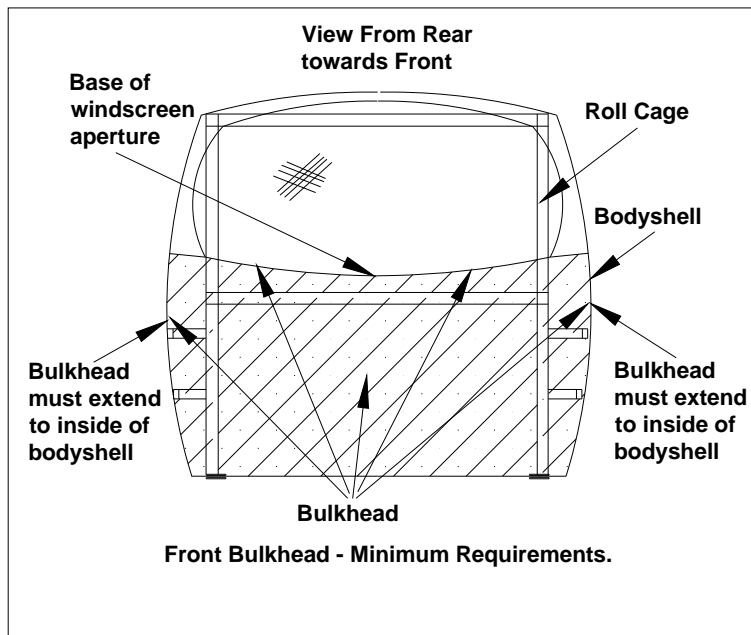

Gij

FIGURE 30 PICK-UP REQUIREMENTS.

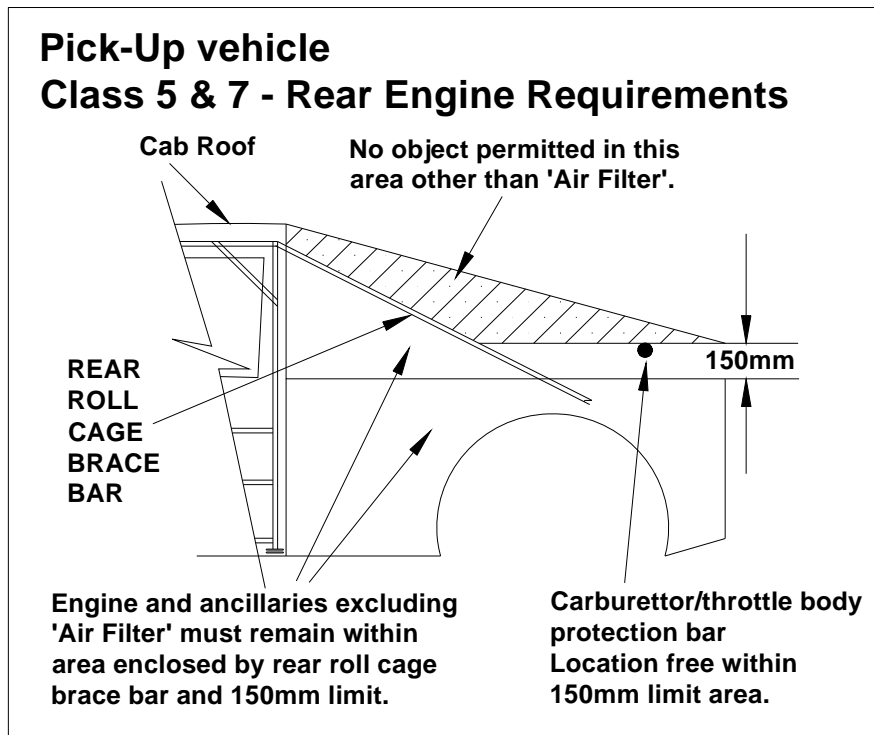

gii

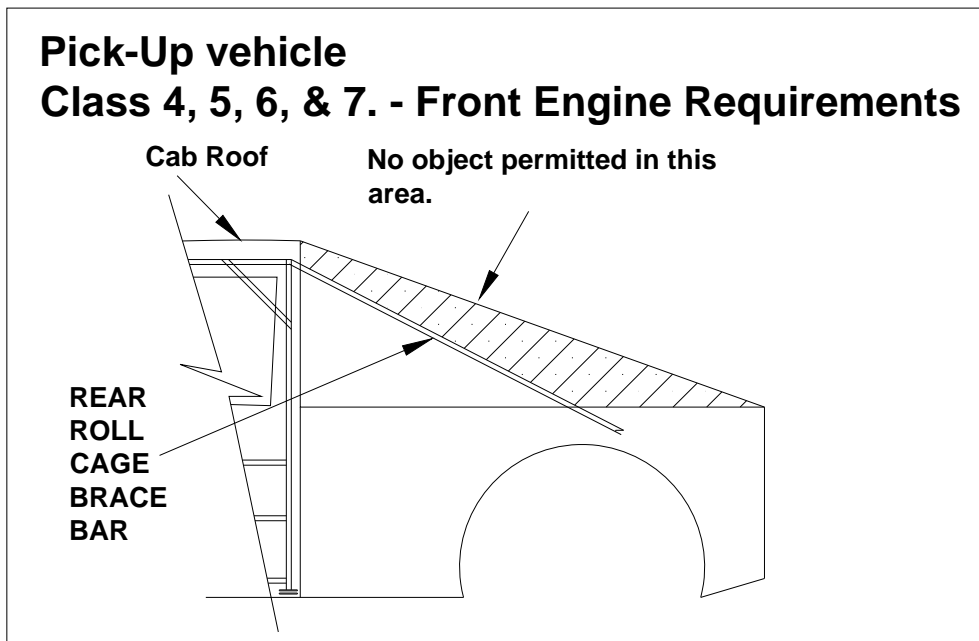

gii

FIGURE 31 REAR BUMPER (Automotive Plastic types only).

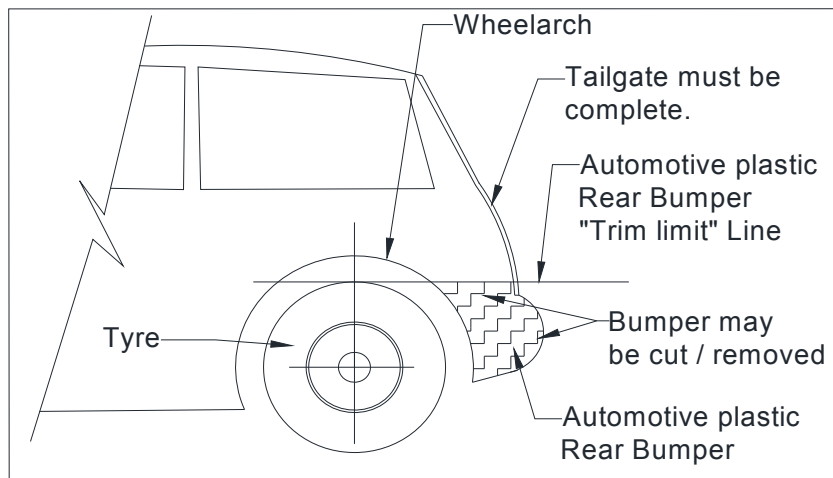

Rear Bumper - Automotive Plastic Type Permitted trim limit.

gij

Figure 32a Front Engine Vehicles. Front Bulkhead /Engine & radiator / Suspension cradle Location.

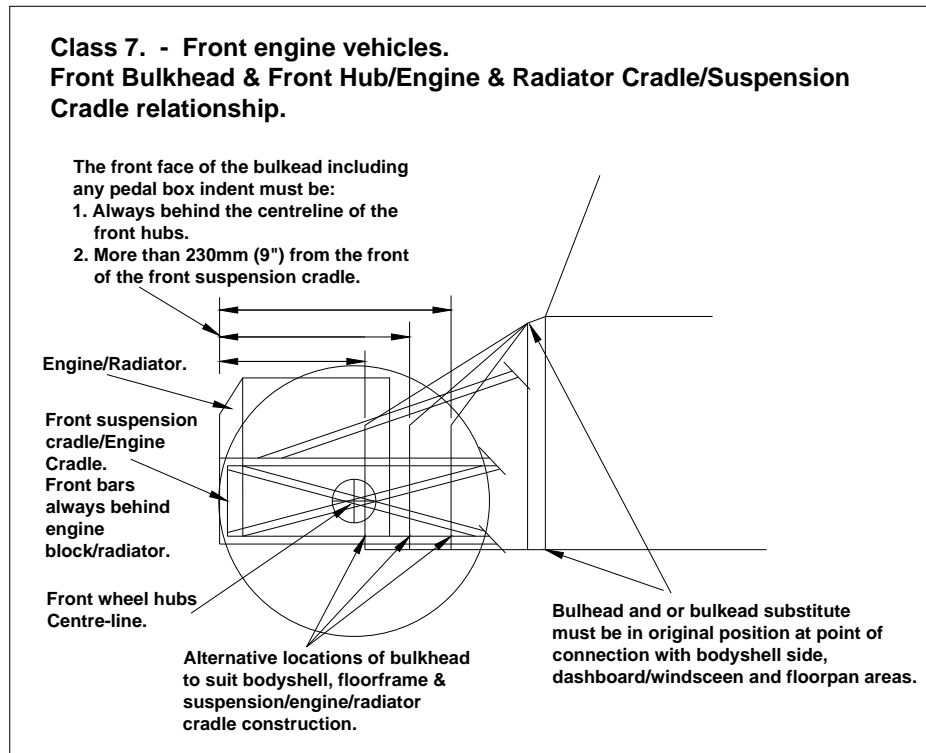

gij

Figure 32b Rear/Mid Engine Vehicles.
Front Bulkhead / Suspension cradle Location.

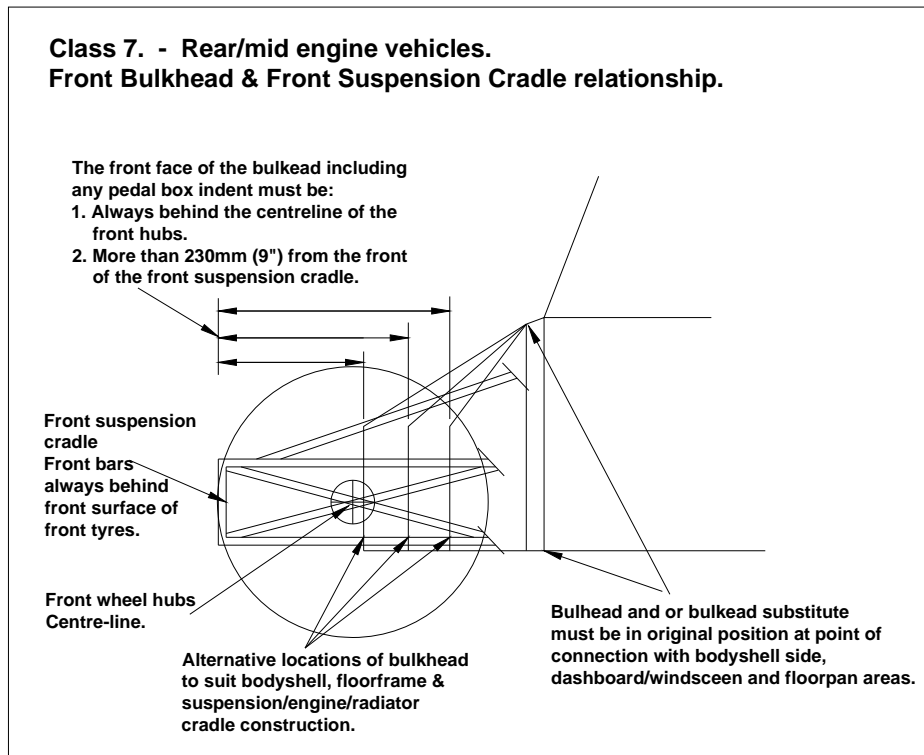

Gij

Figure 33 Control pedal Location.

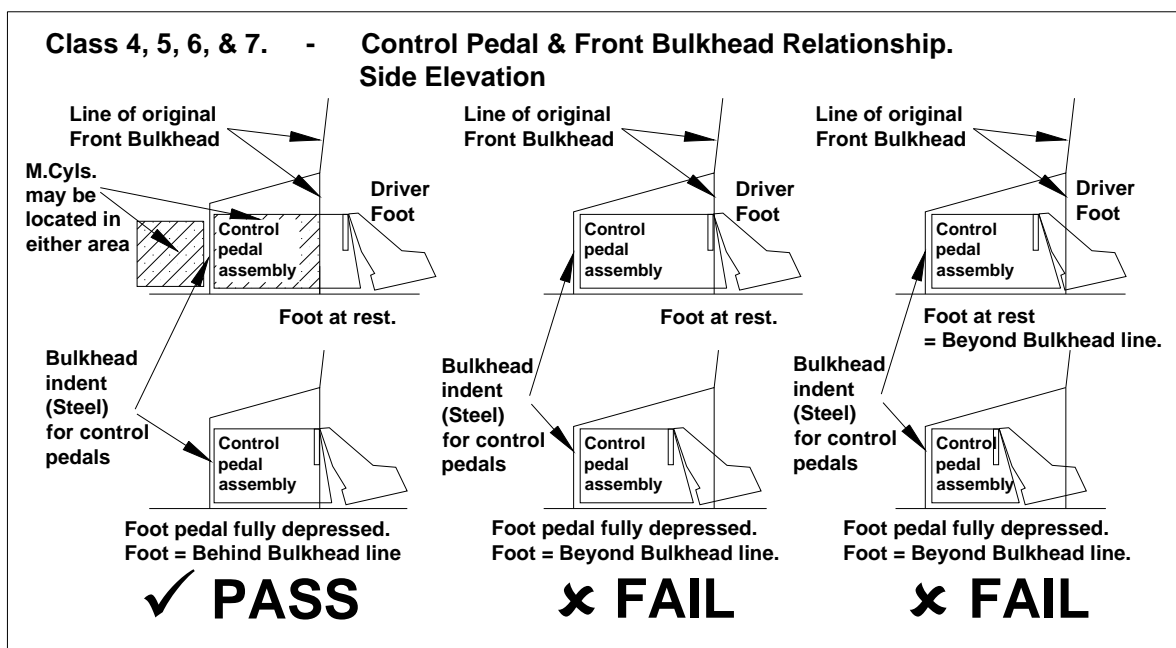

Gij

Figure 35 NASA PICK UP GUIDE.

NASA MINI PICK UP GUIDE

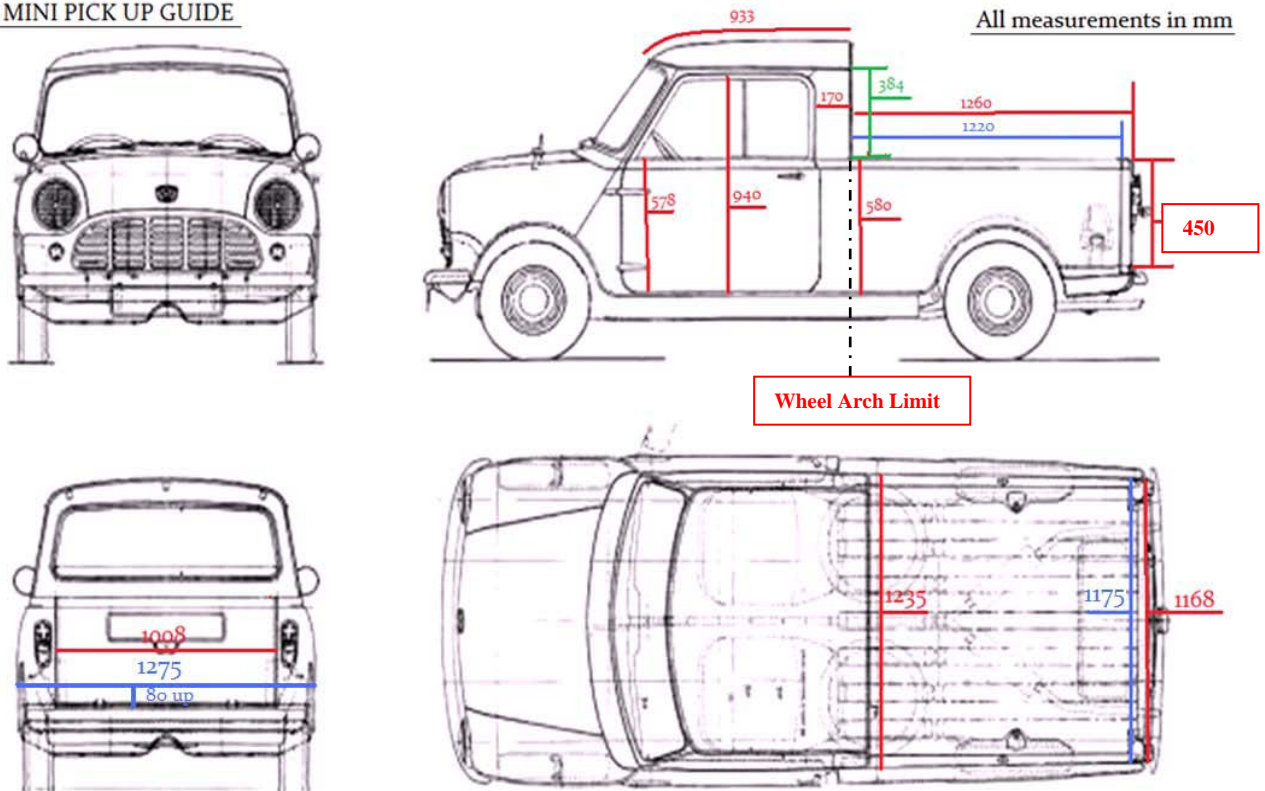

The construction rules in this book are intended for use by Autograss cars taking part in Autograss events as defined by the NATIONAL AUTOGRASS SPORT ASSOCIATION on a natural surface and are not necessarily considered safe for other forms of motor sport.

Drivers are advised that if they intend using their cars at events, other than events as defined by the NATIONAL AUTOGRASS SPORT ASSOCIATION

They should ensure that their cars comply with the organiser's construction rules.

® AUTOGRASS IS A REGISTERED TRADEMARK OF THE NATIONAL AUTOGRASS SPORT ASSOCIATION

© NATIONAL AUTOGRASS SPORT ASSOCIATION LTD 2019